



DATA SHEET

NET WEIGHT 92kg (203lbs)
SHIPPING WEIGHTS 114kg (252lbs)
IMPELLER DIA. 158,75mm (6.1/4")
R.P.M. FROM 1150rpm TO 2900rpm
MAX. SOLIDS 44,45mm (1.3/4")

SELF-PRIMING

1150 RPM 7,3m (24ft) - 1450 RPM 7,6m (25ft)
1750 RPM 7,6m (25ft) - 2050 RPM 7,6m (25ft)
2350 RPM 7,6m (25ft) - 2650 RPM 7,6m (25ft)
2650 RPM 7,6m (25ft) - 2900 RPM 7,6m (25ft)

BEFORE USING THIS TABLE, CHECK THE NPSH.

PERFORMANCE CURVE 2"x2"

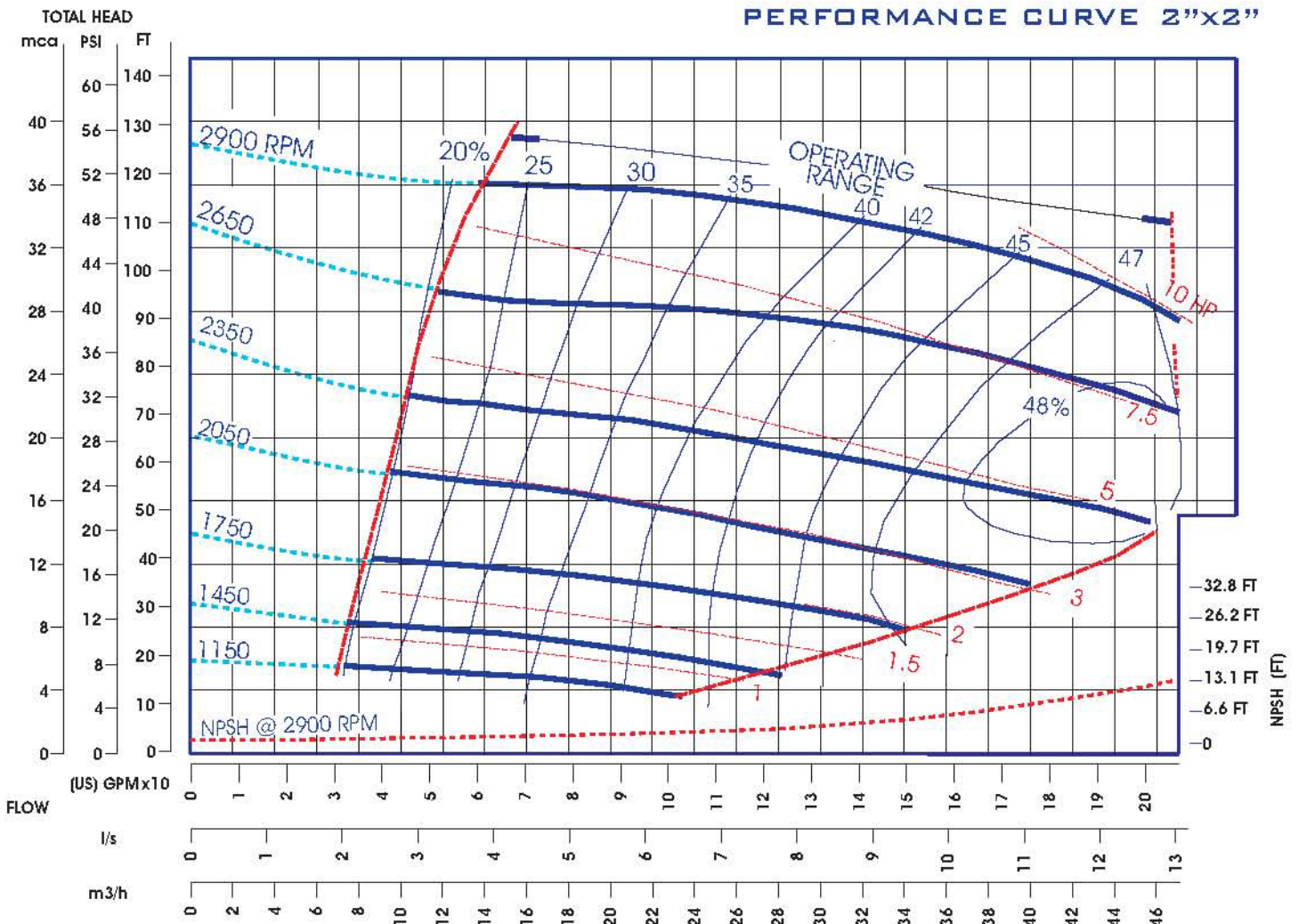

EXTERNAL DIMENSIONS
MILLIMETERS (INCHES)

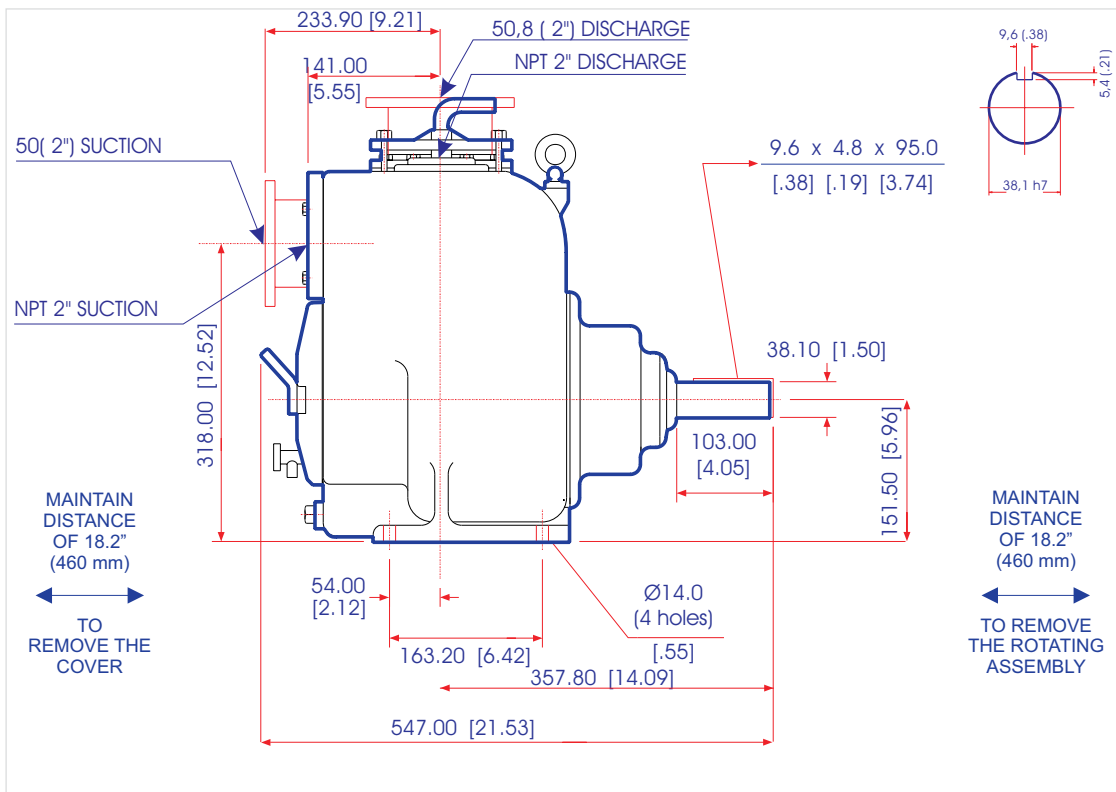
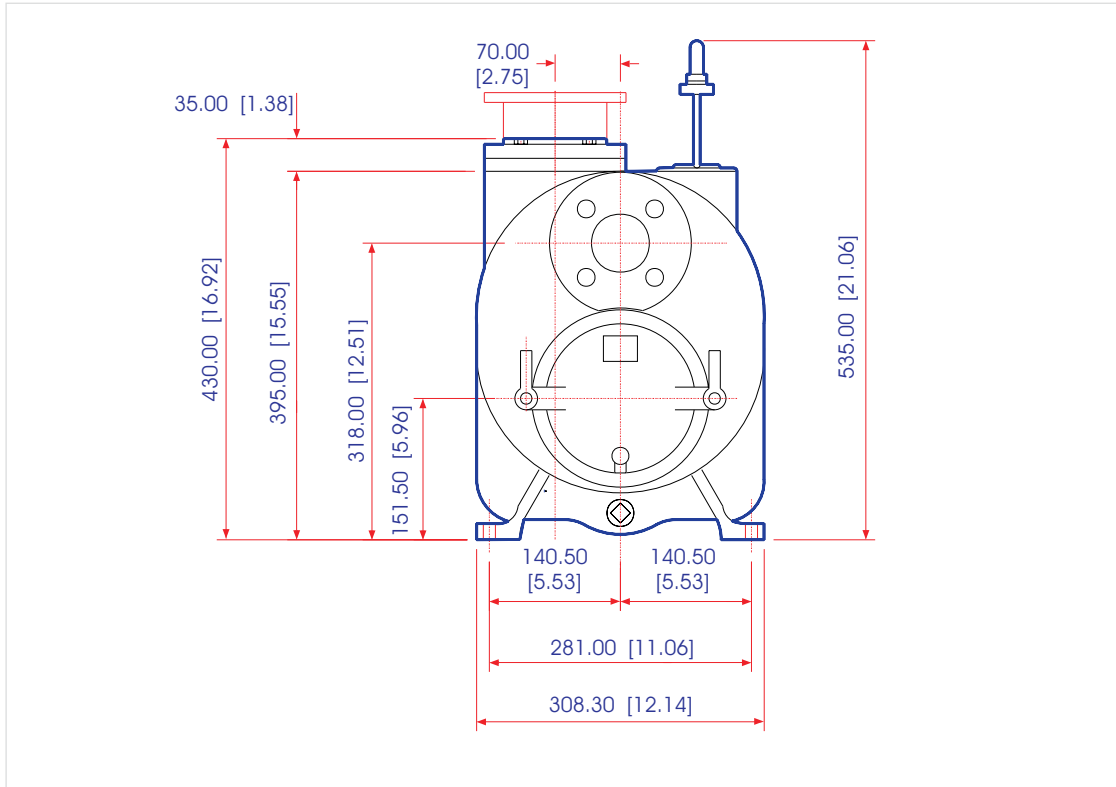



DATA SHEET

NET WEIGHT 183kg (404lbs)
SHIPPING WEIGHTS 205kg (452lbs)
IMPELLER DIA. 222,25mm (8.3/4")
R.P.M. FROM 650rpm TO 2150rpm
MAX. SOLIDS 63,5mm (2.1/2")

SELF-PRIMING

650 RPM 1,5m (5ft) - 750 RPM 1,8m (6ft)
 850 RPM 2,4m (8ft) - 950 RPM 3,0m (10ft)
 1050 RPM 4,0m (13ft) - 1150 RPM 4,9m (16ft)
 1250 RPM 5,5m (18ft) - 1350 RPM 5,8m (19ft)
 1450 RPM 6,4m (21ft) - 1550 RPM 6,4m (21ft)
 1650 RPM 6,7m (22ft) - 1750 RPM 6,7m (22ft)
 1850 RPM 7,6m (25ft) - 1950 RPM 7,6m (25ft)
 2050 RPM 7,6m (25ft) - 2150 RPM 7,6m (25ft)

BEFORE USING THIS TABLE, CHECK THE NPSH.

PERFORMANCE CURVE 3"x3"

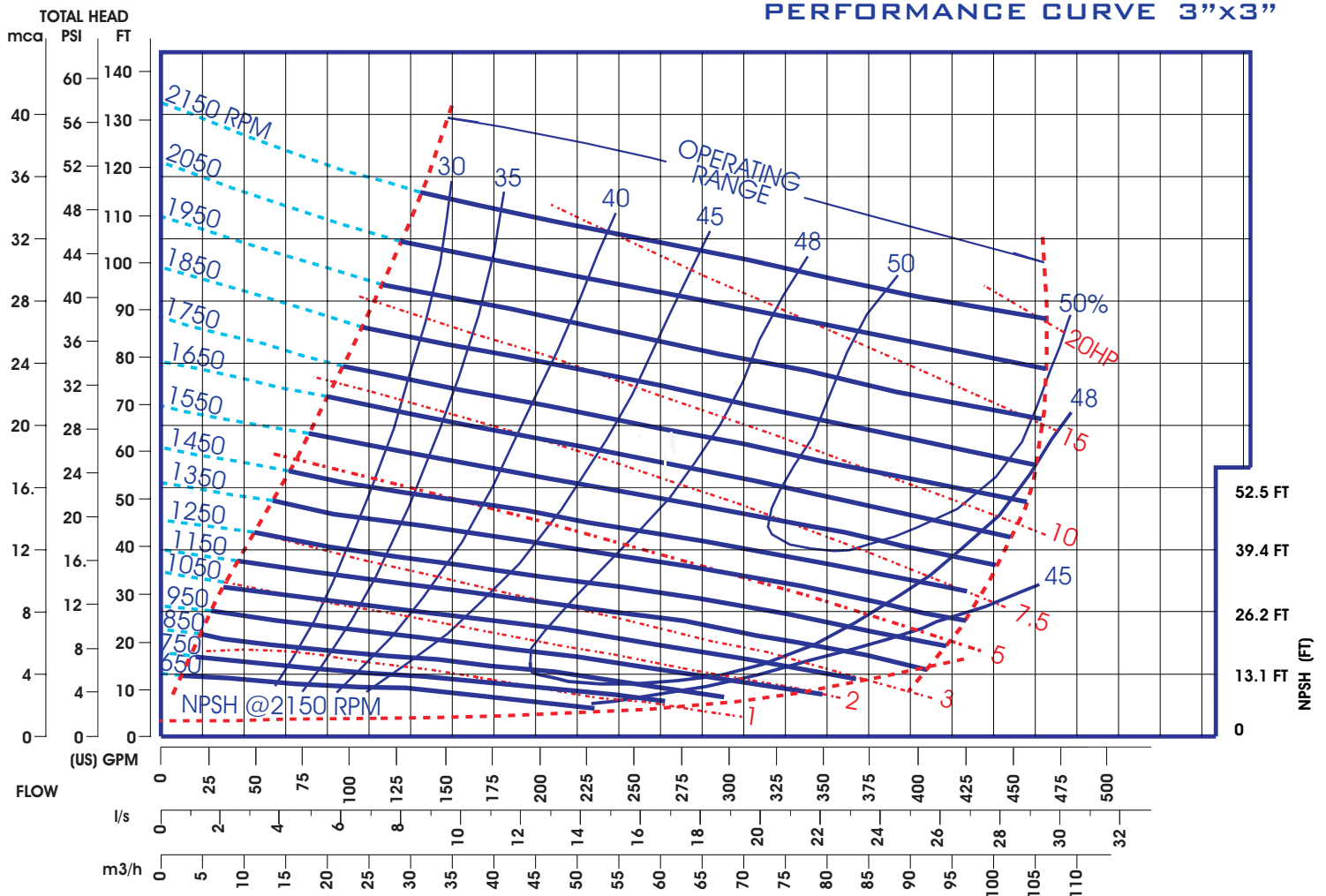

EXTERNAL DIMENSIONS
MILLIMETERS (INCHES)

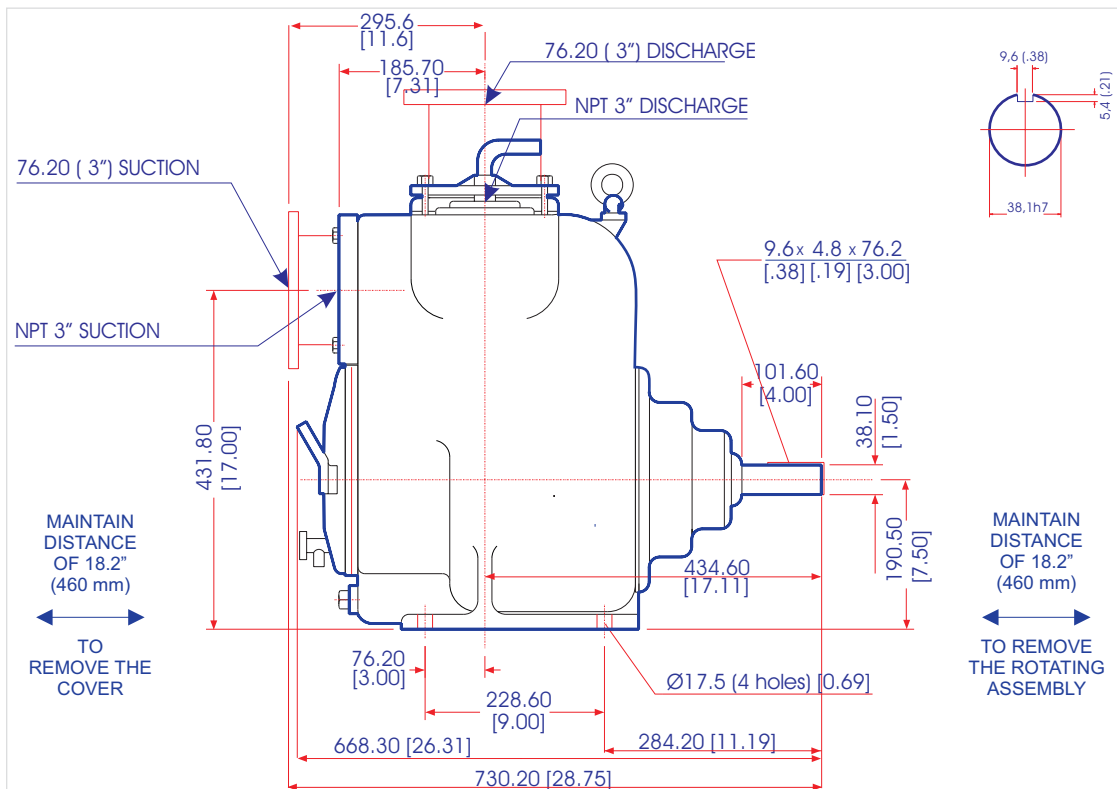
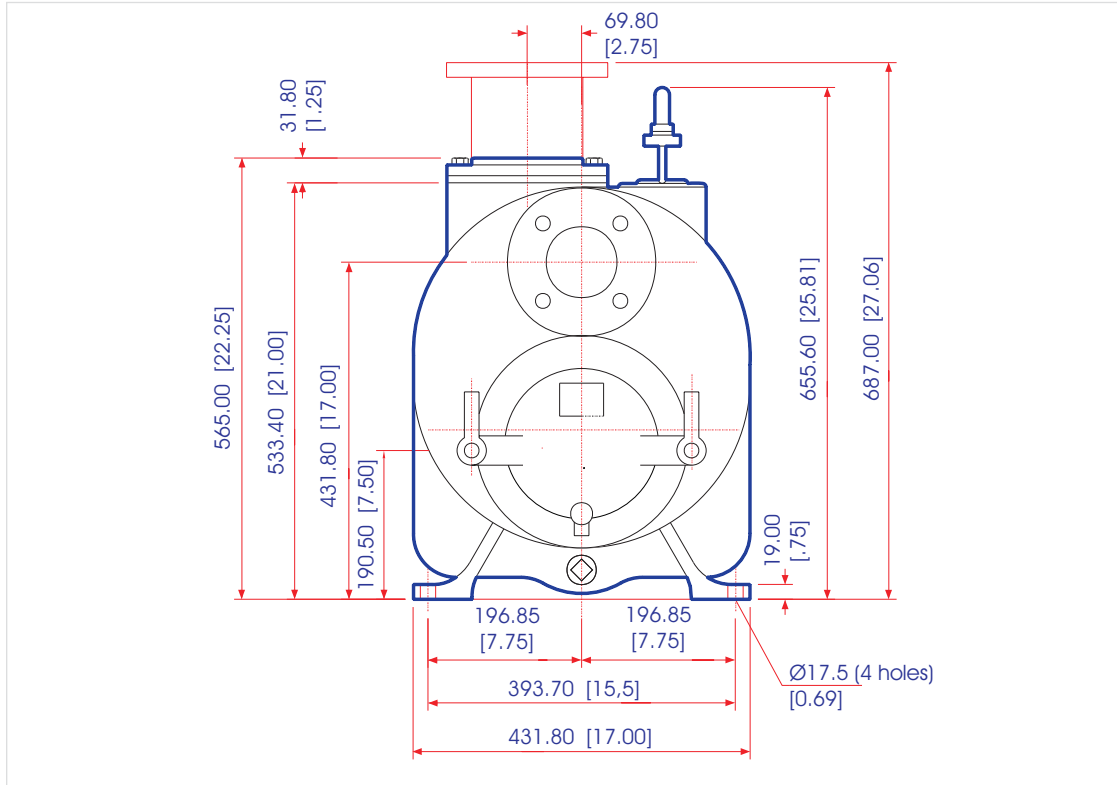



DATA SHEET

NET WEIGHT 259,5kg (600lbs)
SHIPPING WEIGHTS 280kg (655lbs)
IMPELLER DIA. 247,65mm (9.3/4")
R.P.M. FROM 650rpm TO 1950rpm
MAX. SOLIDS 76,2mm (3")

SELF-PRIMING

650 RPM 1,5m (5ft) - 750 RPM 2,4m (8ft)
 850 RPM 4,9m (16ft) - 950 RPM 5,8m (19ft)
 1050 RPM 6,7m (22ft) - 1150 RPM 7,3m (24ft)
 1250 RPM 7,6m (25ft) - 1350 RPM 7,6m (25ft)
 1450 RPM 7,6m (25ft) - 1550 RPM 7,6m (25ft)
 1650 RPM 7,6m (25ft) - 1750 RPM 7,6m (25ft)
 1850 RPM 7,6m (25ft) - 1950 RPM 7,6m (25ft)

BEFORE USING THIS TABLE, CHECK THE NPSH.

PERFORMANCE CURVE 4"x4"

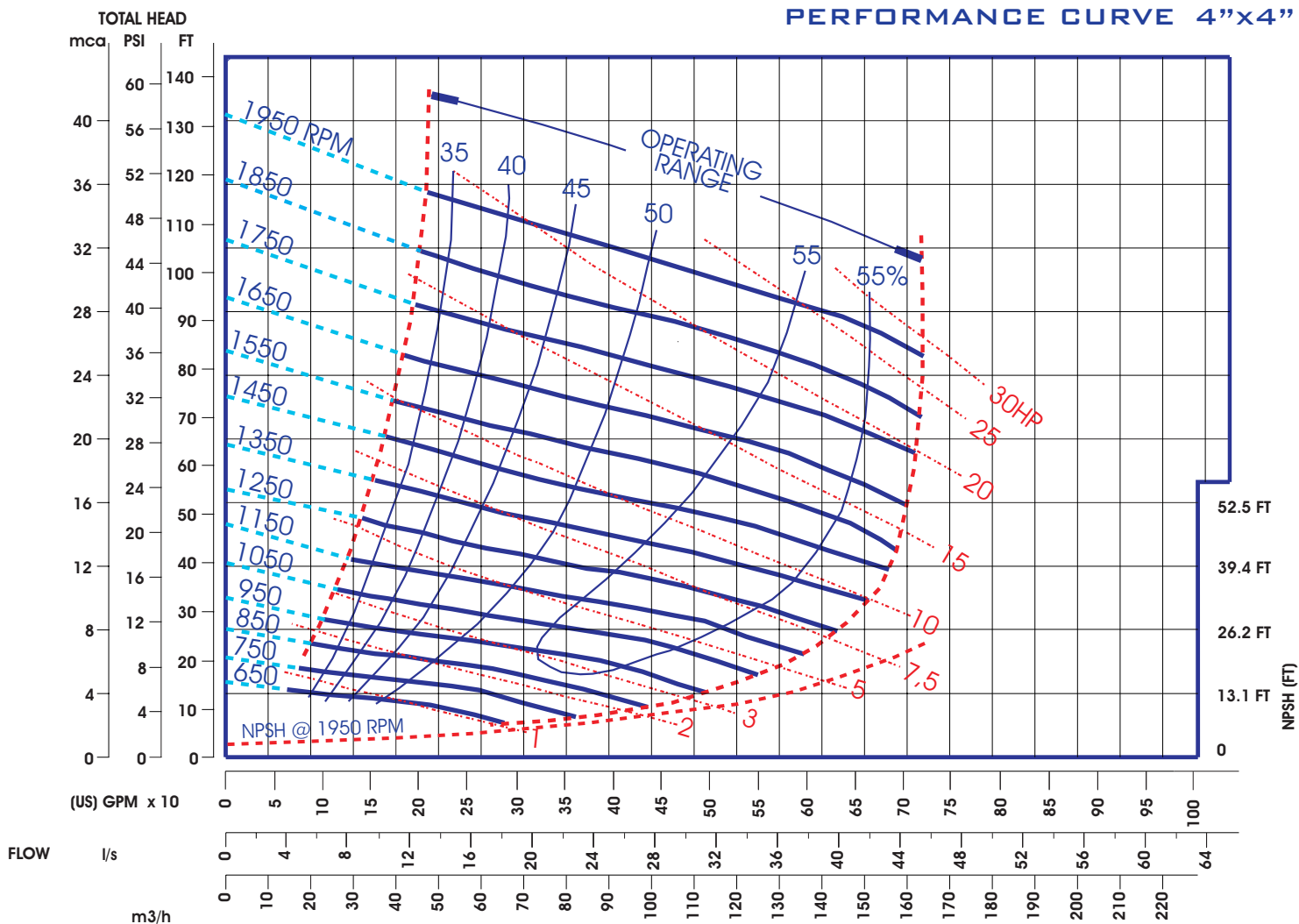



KTP

KAMYAR TAJHIZ POOYA CO.

SERIES P

MODEL P-4

EXTERNAL DIMENSIONS MILLIMETERS (INCHES)

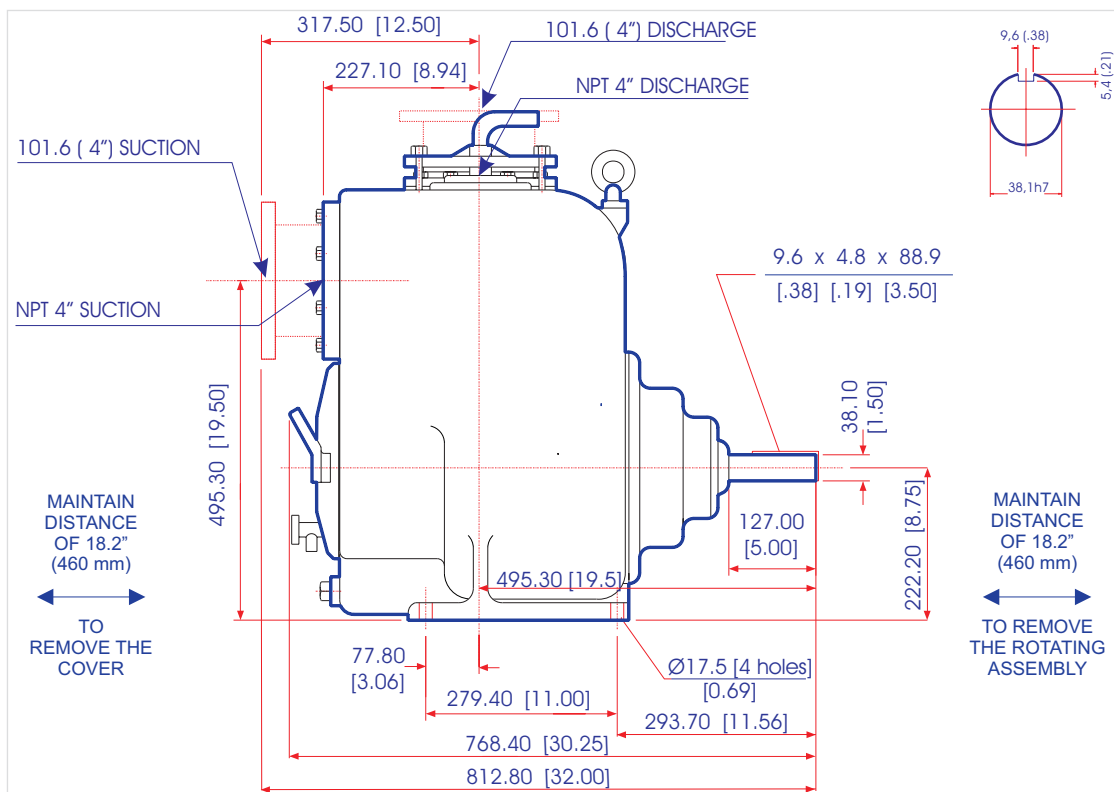
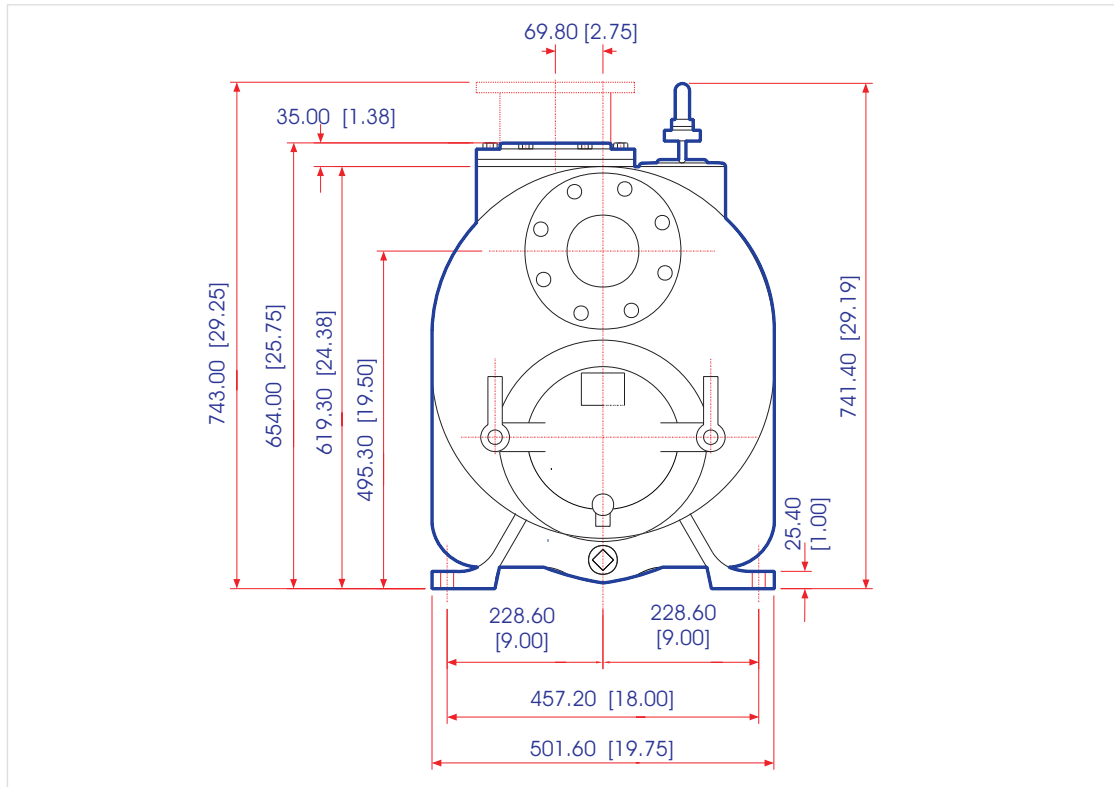

SERIES P

MODEL P-6



DATA SHEET

NET WEIGHT 364kg (802lbs)
SHIPPING WEIGHTS 391kg (862lbs)
IMPELLER DIA. 314,32mm (12.3/8")
R.P.M. FROM 650rpm TO 1550rpm
MAX. SOLIDS 76,2mm (3")

SELF-PRIMING

650 RPM 2,4m (8ft) - 750 RPM 2,7m (9ft)
 850 RPM 3,6m (12ft) - 950 RPM 4,2m (14ft)
 1050 RPM 5,5m (18ft) - 1150 RPM 6,4m (21ft)
 1250 RPM 6,4m (21ft) - 1350 RPM 6,7m (22ft)
 1450 RPM 7,0m (23ft) - 1550 RPM 7,6m (25ft)
 BEFORE USING THIS TABLE, CHECK THE NPSH.

PERFORMANCE CURVE 6"x6"

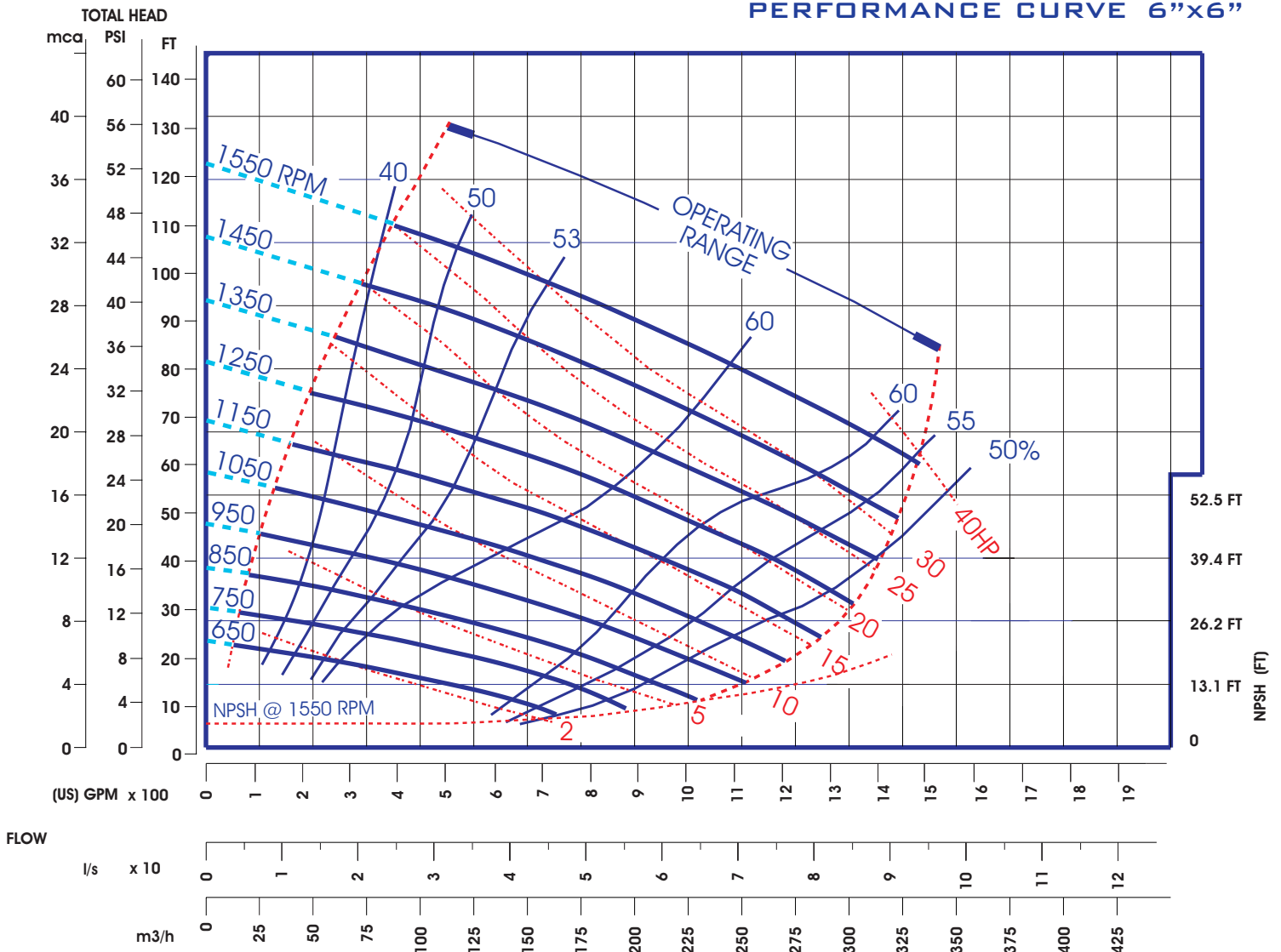

EXTERNAL DIMENSIONS
MILLIMETERS (INCHES)

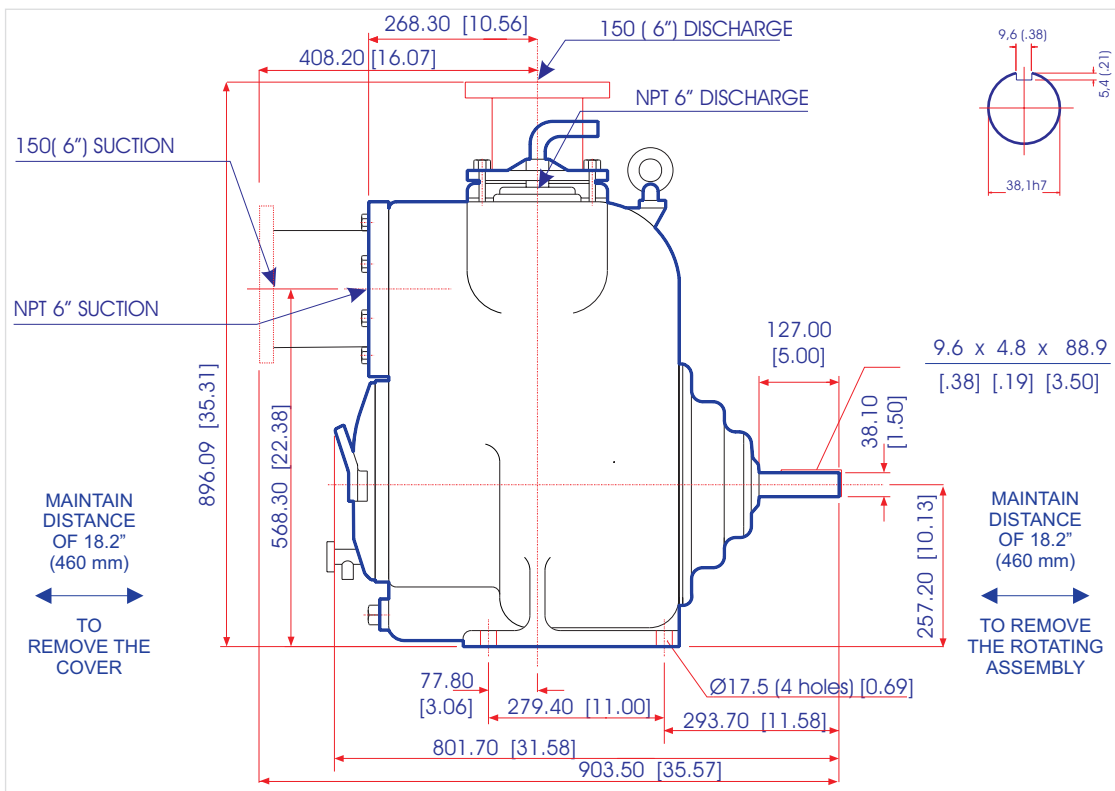
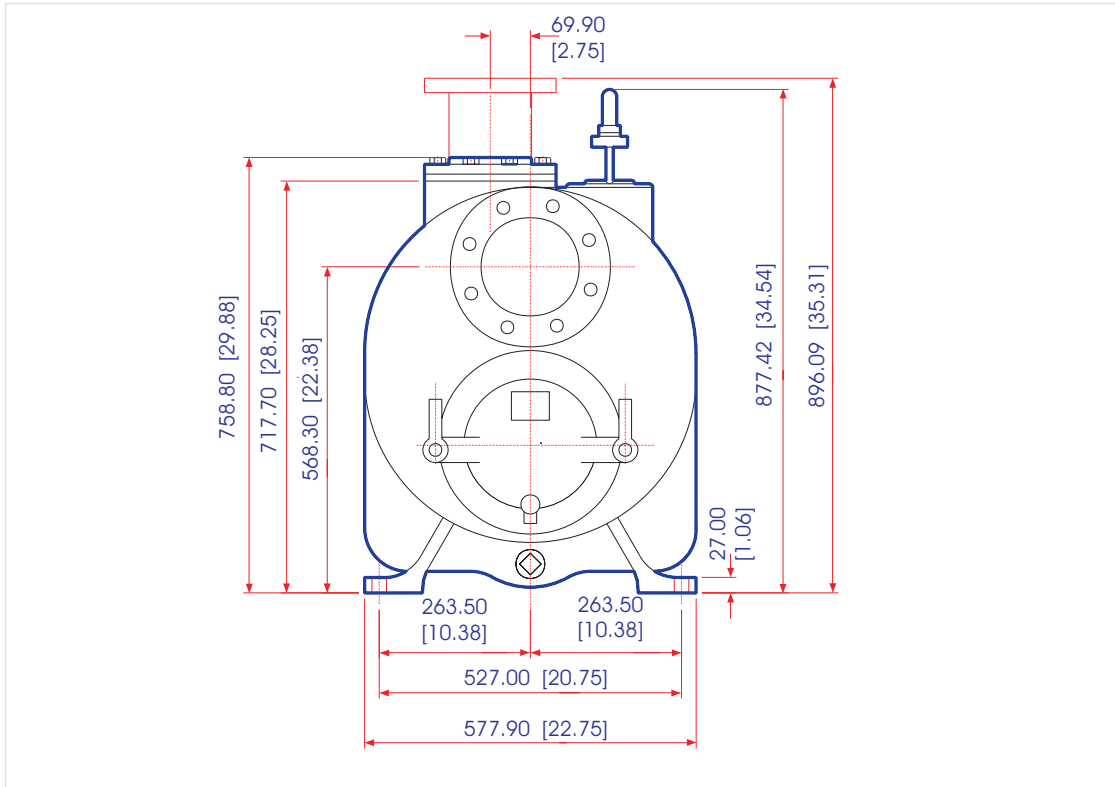



DATA SHEET

NET WEIGHT 581 kg (1295lbs)
SHIPPING WEIGHTS 634kg (1399lbs)
IMPELLER DIA. 374.65mm (14.3/4")
R.P.M. FROM 650rpm TO 1350rpm
MAX. SOLIDS 76,2mm (3")

SELF-PRIMING

650 RPM 2,7m (9ft) - 750 RPM 3,7m (12ft)
 850 RPM 4,6m (15ft) - 950 RPM 5,2m (17ft)
 1050 RPM 6,1m (20ft) - 1150 RPM 6,4m (21ft)
 1250 RPM 6,7m (22ft) - 1350 RPM 7,0m (23ft)

BEFORE USING THIS TABLE, CHECK THE NPSH.

PERFORMANCE CURVE 8"x8"

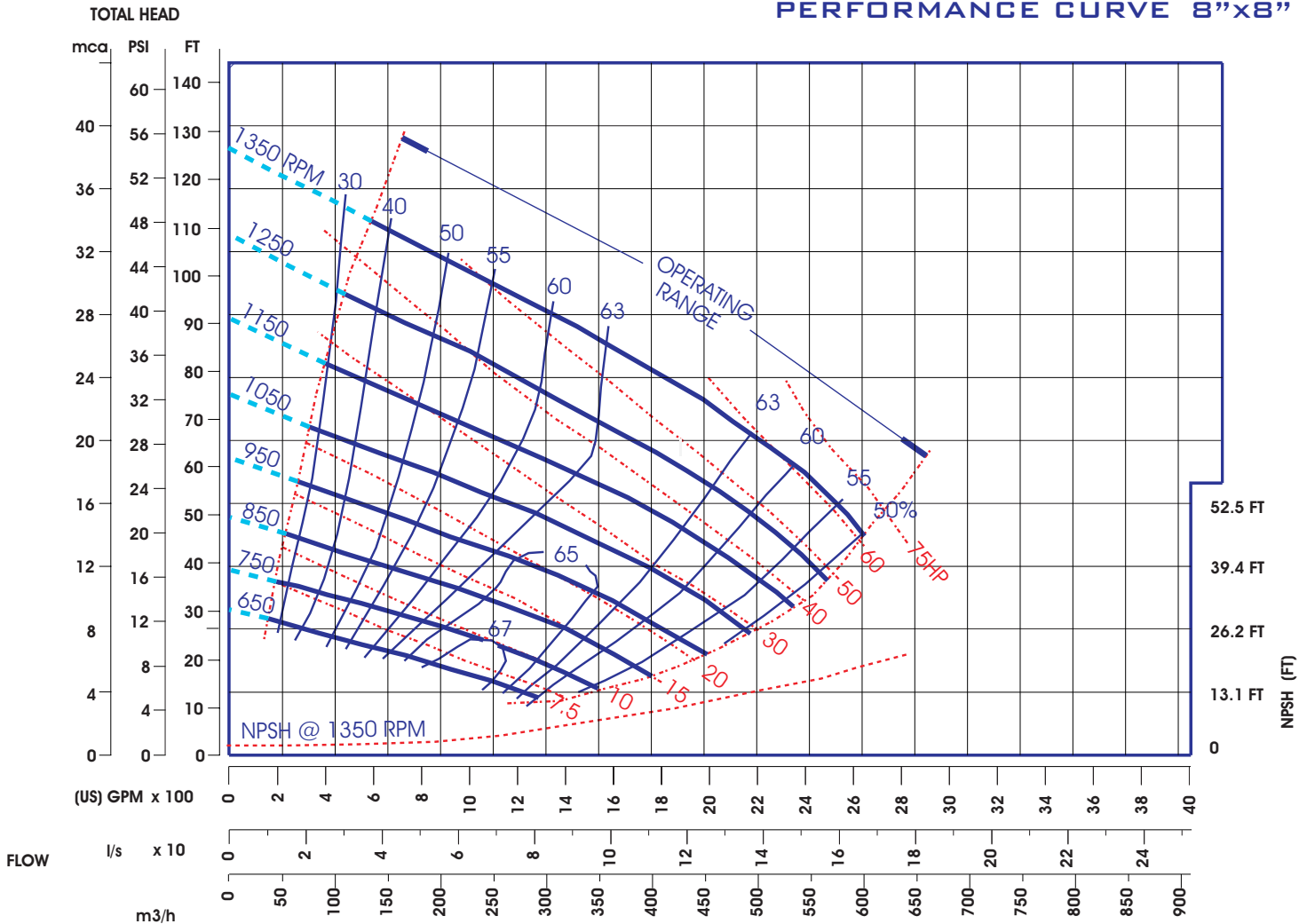

EXTERNAL DIMENSIONS
MILLIMETERS (INCHES)

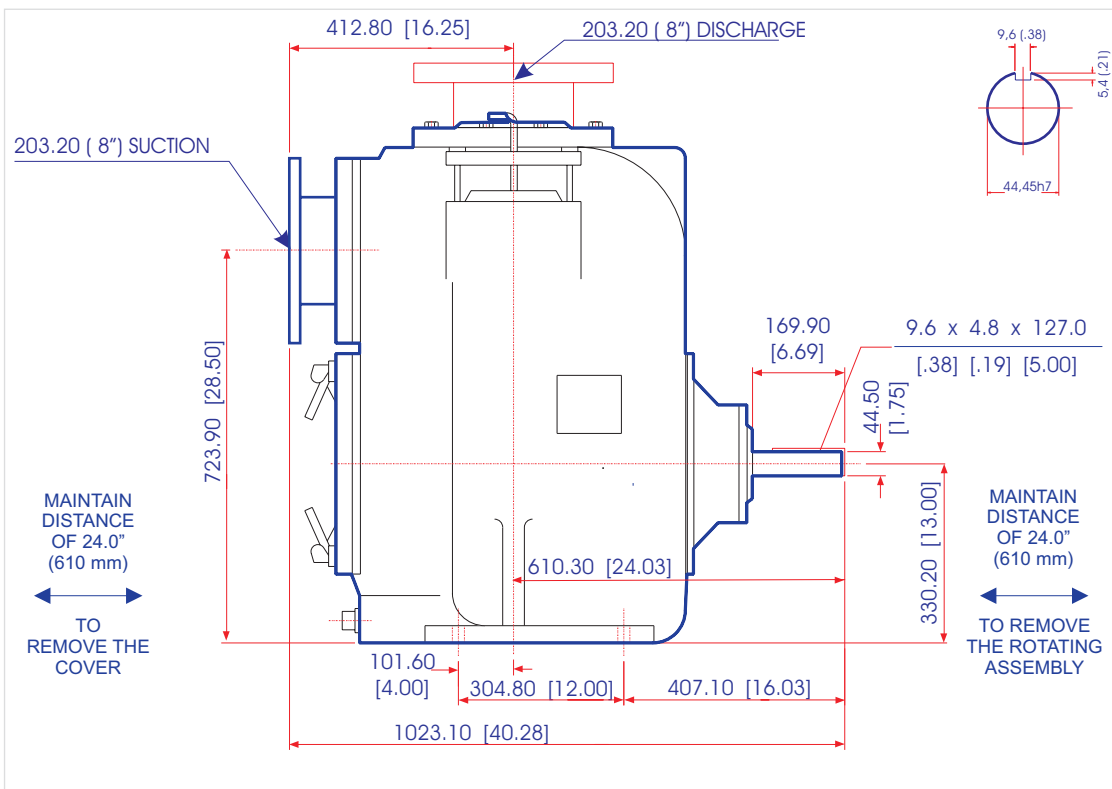
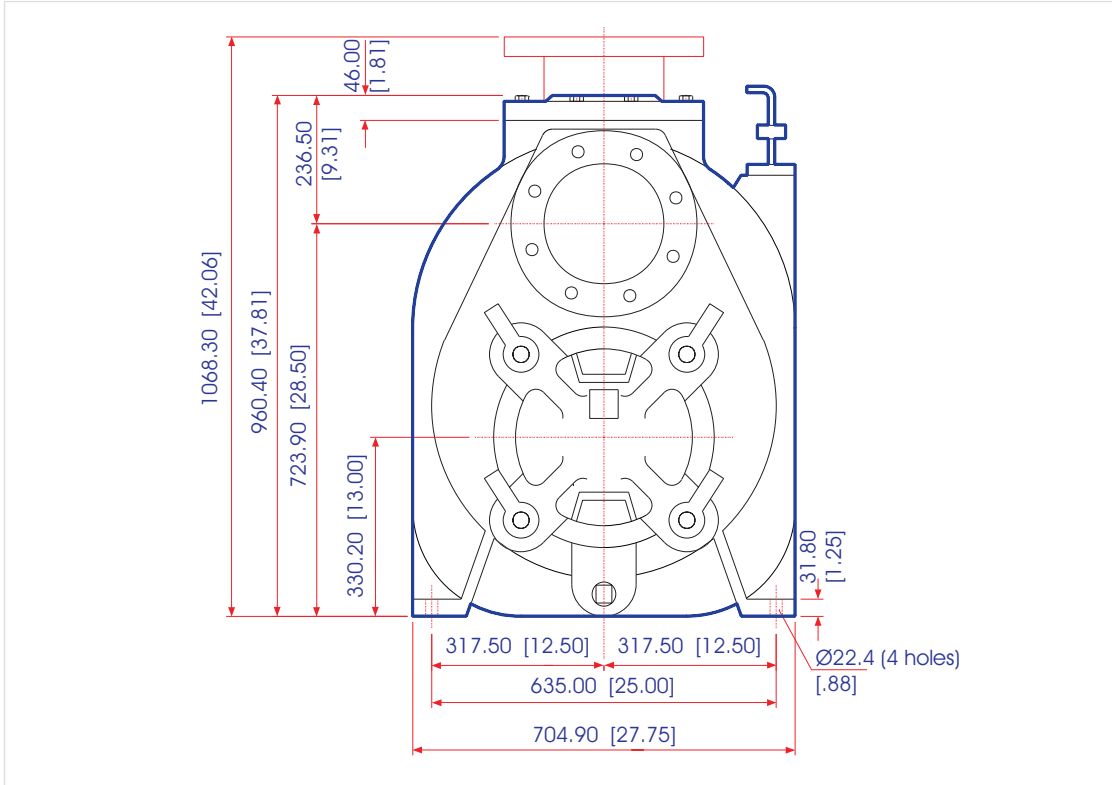



KTP

KAMYAR TAJHIZ POOYA CO.

SERIES P

MODEL P-10



DATA SHEET

NET WEIGHT 635kg (1400lbs)
SHIPPING WEIGHTS 663kg (1461lbs)
IMPELLER DIA. 374,65mm (14.3/4")
R.P.M. FROM 650rpm TO 1450rpm
MAX. SOLIDS 76,2mm (3")

SELF-PRIMING

650 RPM 2,1m (7ft) - 750 RPM 3,4m (11ft)
 850 RPM 4,3m (14ft) - 950 RPM 5,2m (17ft)
 1050 RPM 5,5m (18ft) - 1150 RPM 5,5m (18ft)
 1250 RPM 5,8m (19ft) - 1350 RPM 6,7m (22ft)
 1450 RPM 6,7m (22ft)

BEFORE USING THIS TABLE, CHECK THE NPSH.

PERFORMANCE CURVE 10"x10"

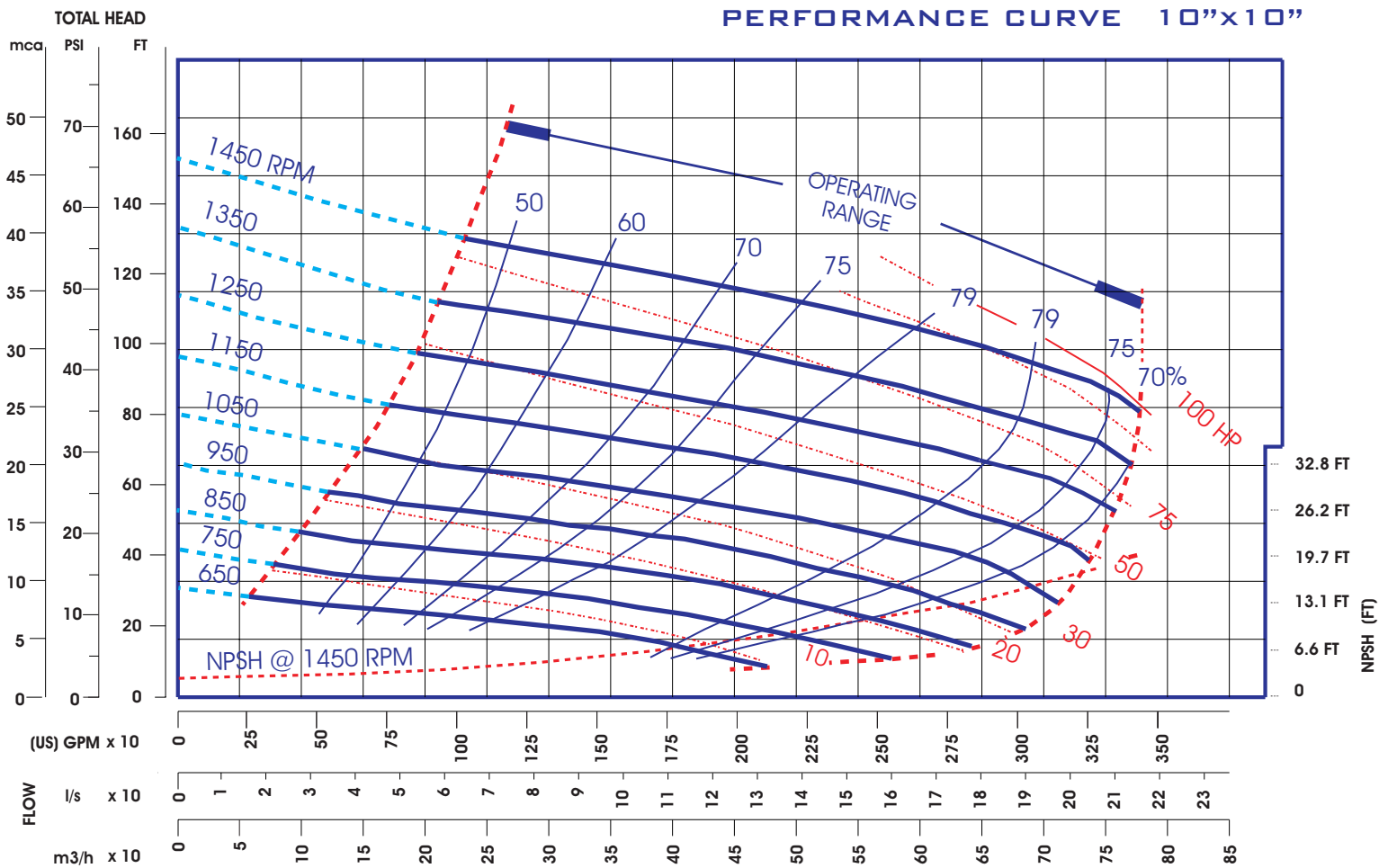

**EXTERNAL DIMENSIONS
MILLIMETERS (INCHES)**

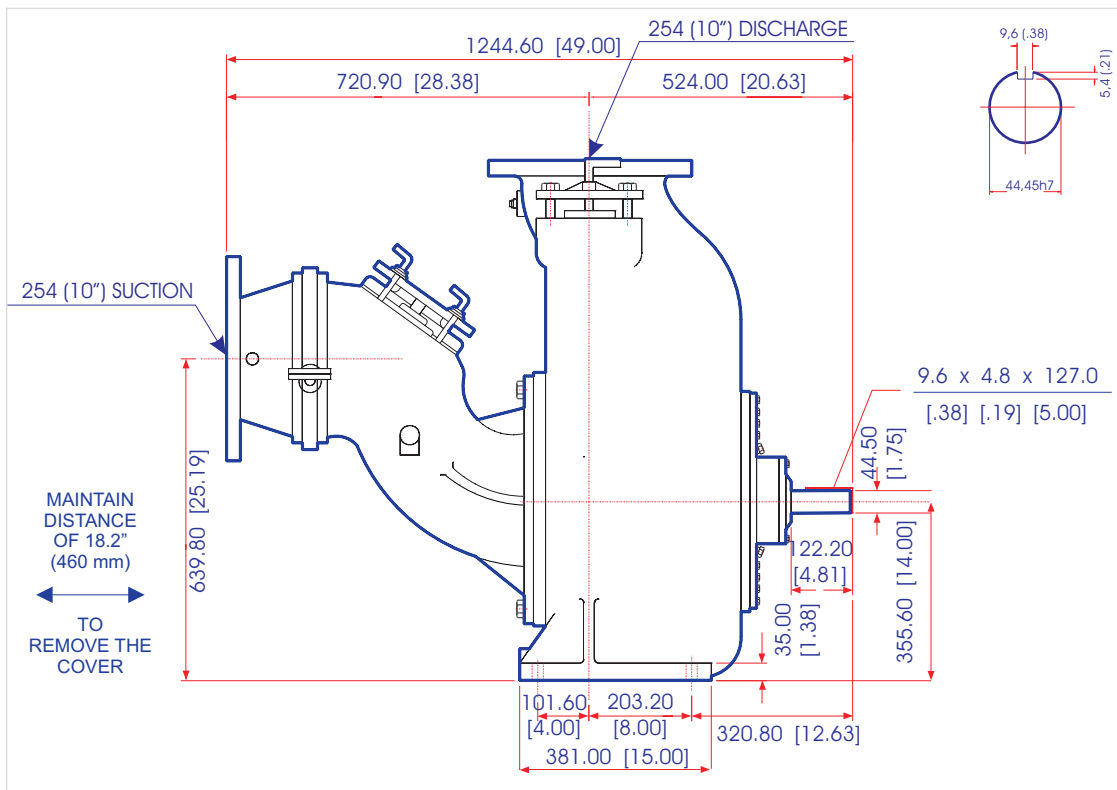
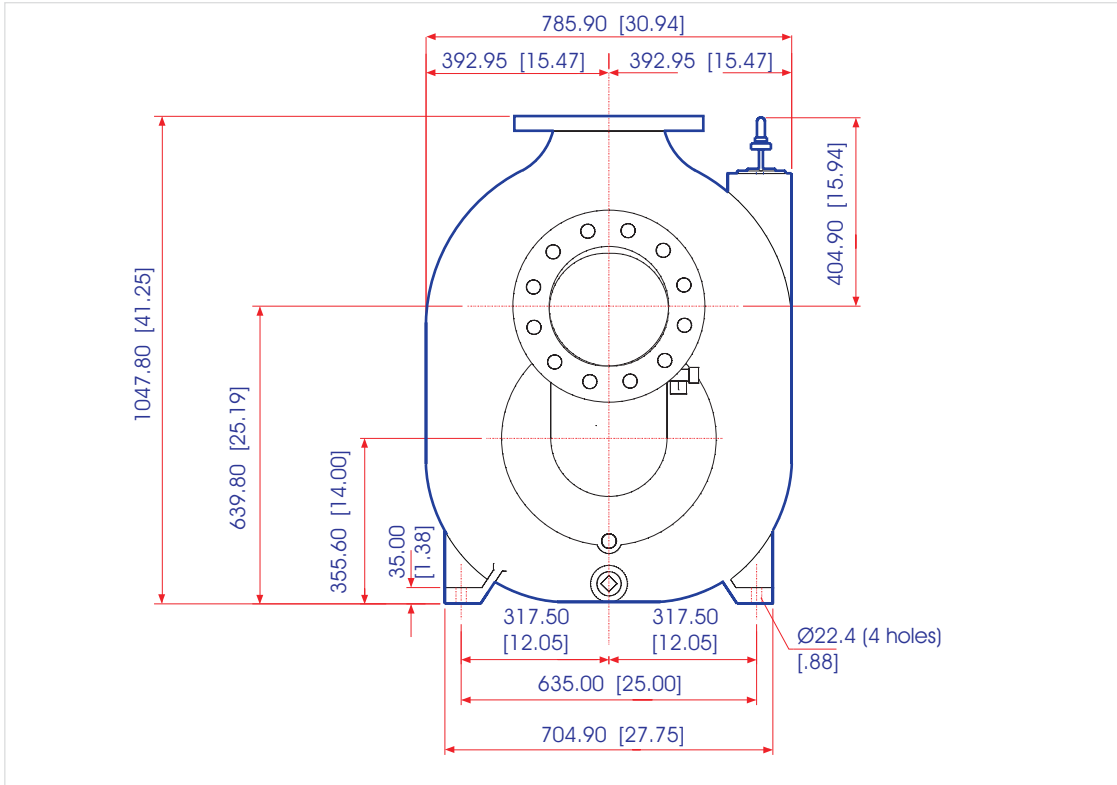



KTP

KAMYAR TAJHIZ POOYA CO.

SERIES P

MODEL P-12



DATA SHEET

NET WEIGHT **998kg (2200lbs)**
 SHIPPING WEIGHTS **1066kg (2350lbs)**
 IMPELLER DIA. **457,2mm (18")**
 R.P.M. **FROM 650rpm TO 1250rpm**
 MAX. SOLIDS **76,2mm (3")**

SELF-PRIMING

650 RPM 1,6m (5ft) - 750 RPM 2,7m (9ft)
 850 RPM 3,9m (13ft) - 950 RPM 4,5m (15ft)
 1050 RPM 4,9m (16ft) - 1150 RPM 4,9m (16ft)
 1250 RPM 4,9m (16ft)

BEFORE USING THIS TABLE, CHECK THE NPSH.

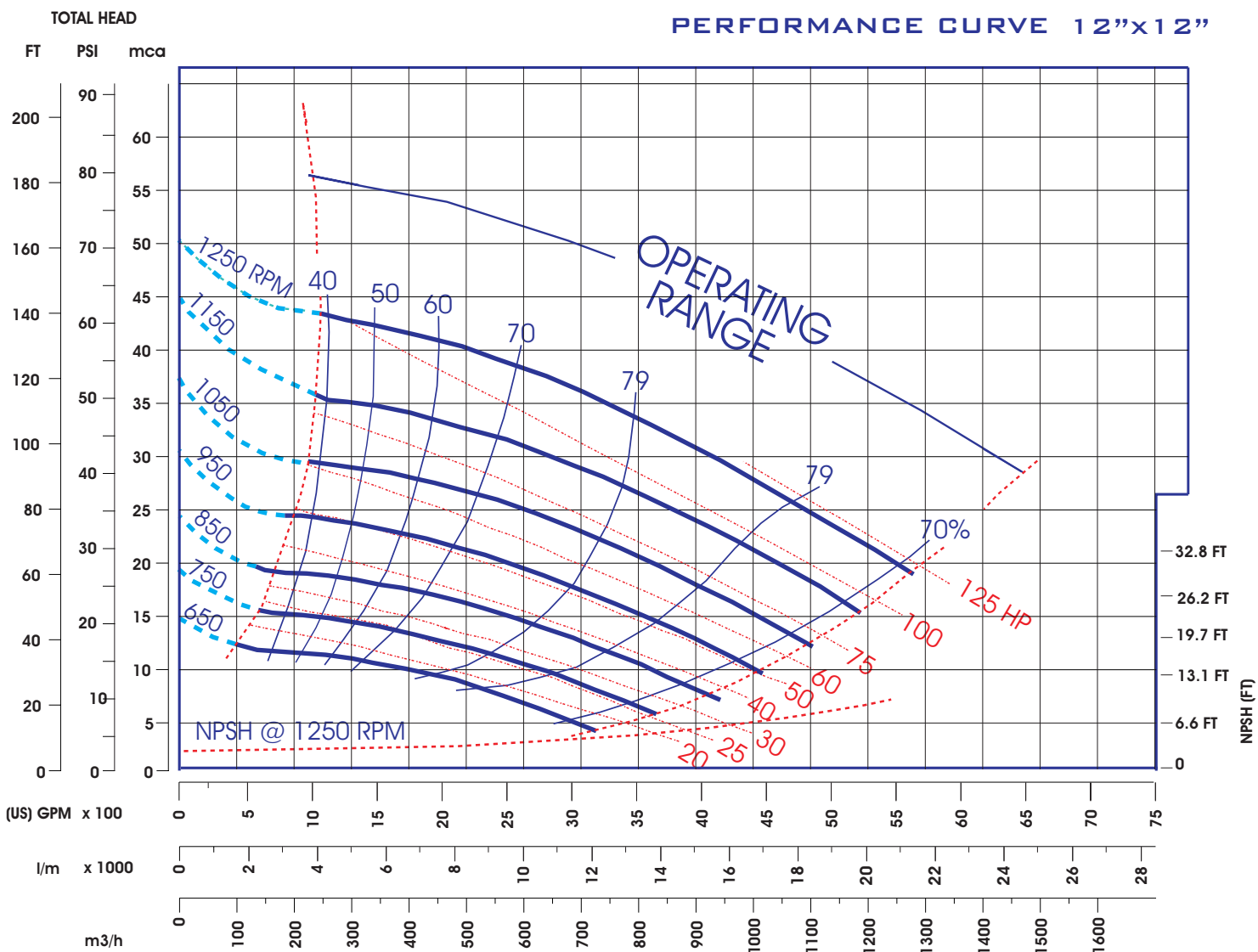



KTP

KAMYAR TAJHIZ POOYA CO.

SERIES P

MODEL P-12

EXTERNAL DIMENSIONS
MILLIMETERS

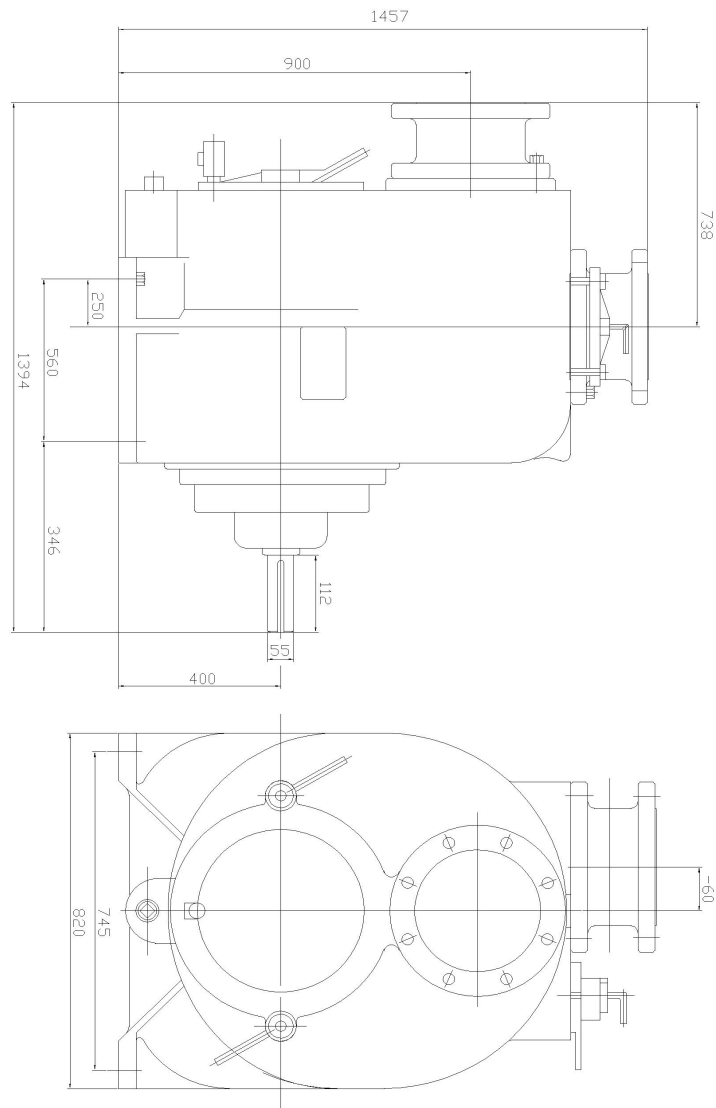



DATA SHEET

NET WEIGHT 214kg (472lbs)
SHIPPING WEIGHTS 225kg (497lbs)
IMPELLER DIA. 279,4mm (11")
R.P.M. FROM 850rpm TO 2150rpm
MAX. SOLIDS 20.63mm (13/16")

SELF-PRIMING

850 RPM 2,3m (7ft) - 1150 RPM 2,9m (9ft)
 1450 RPM 4,5m (15ft) - 1750 RPM 7,6m (25ft)
 1950 RPM 7,6m (25ft) - 2150 RPM 7,6m (25ft)

BEFORE USING THIS TABLE, CHECK THE NPSH.

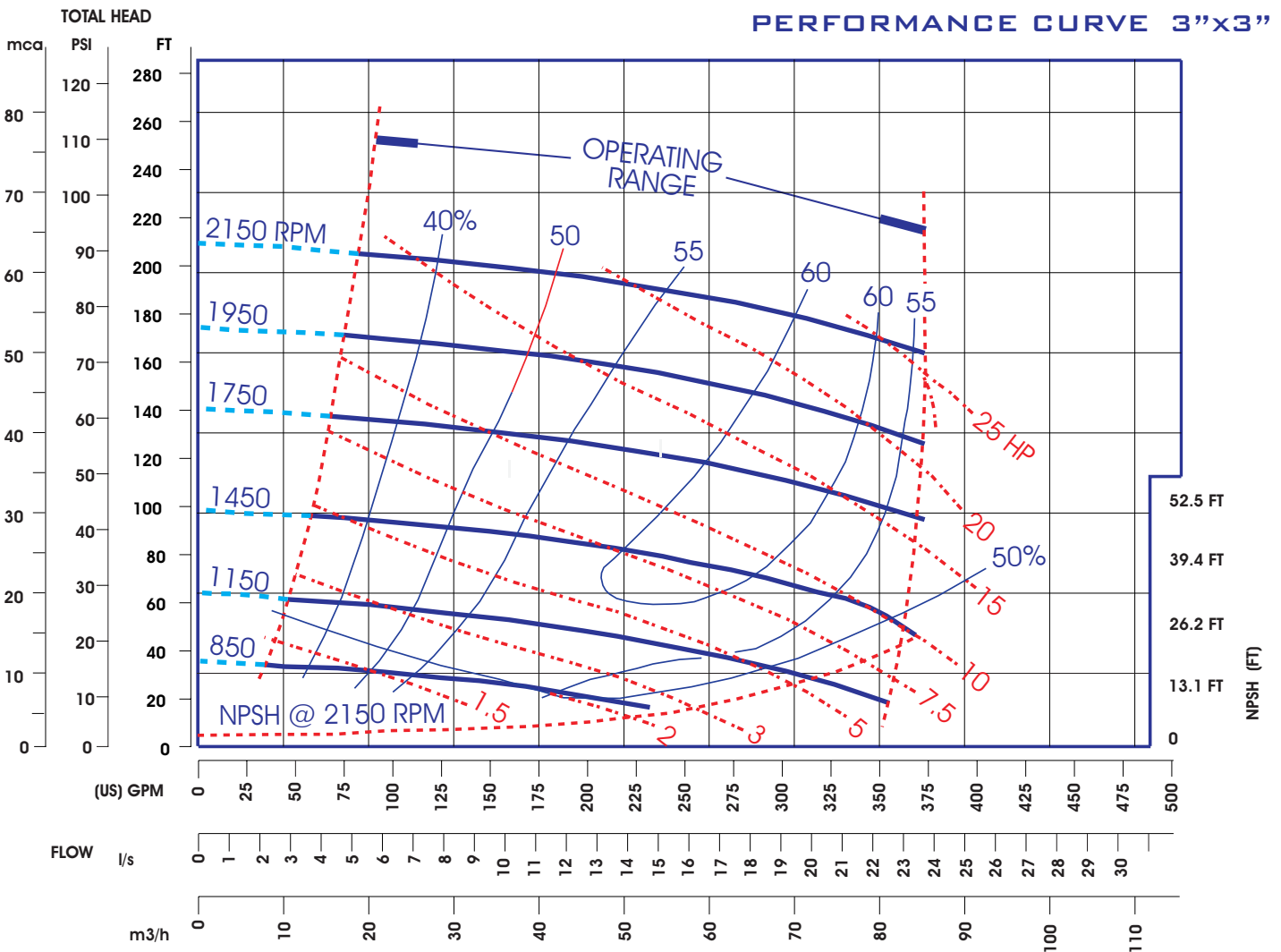

EXTERNAL DIMENSIONS
MILLIMETERS (INCHES)

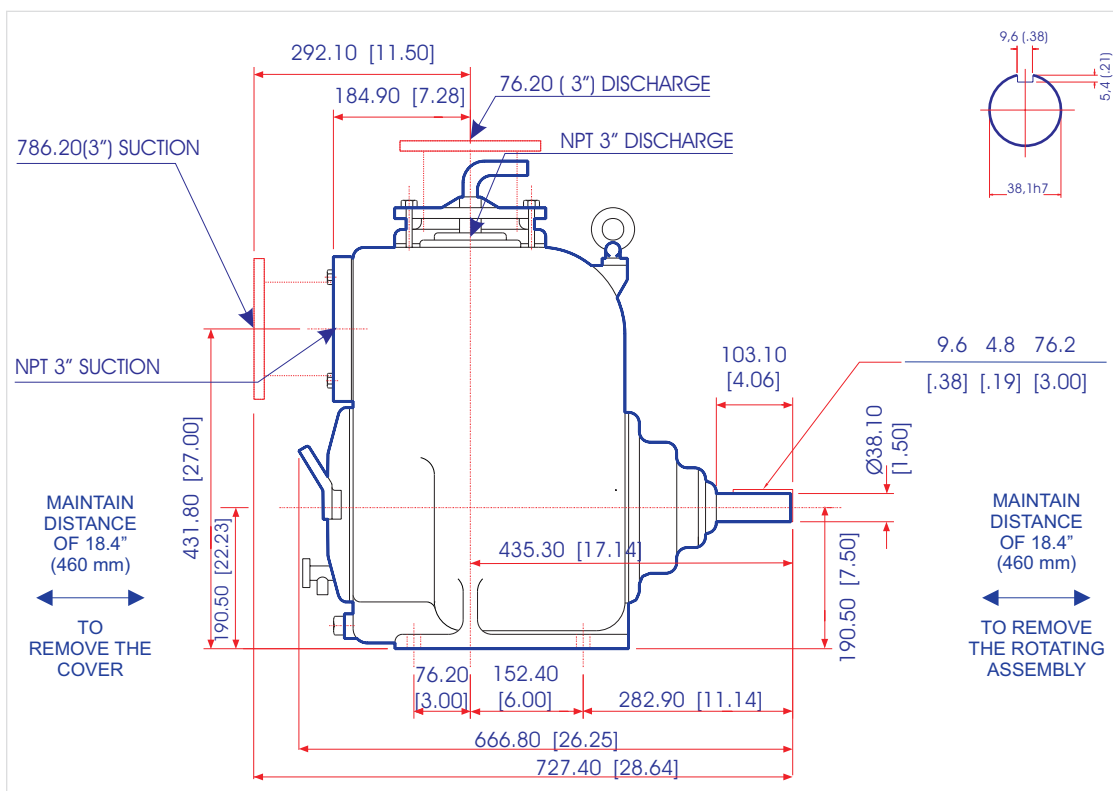
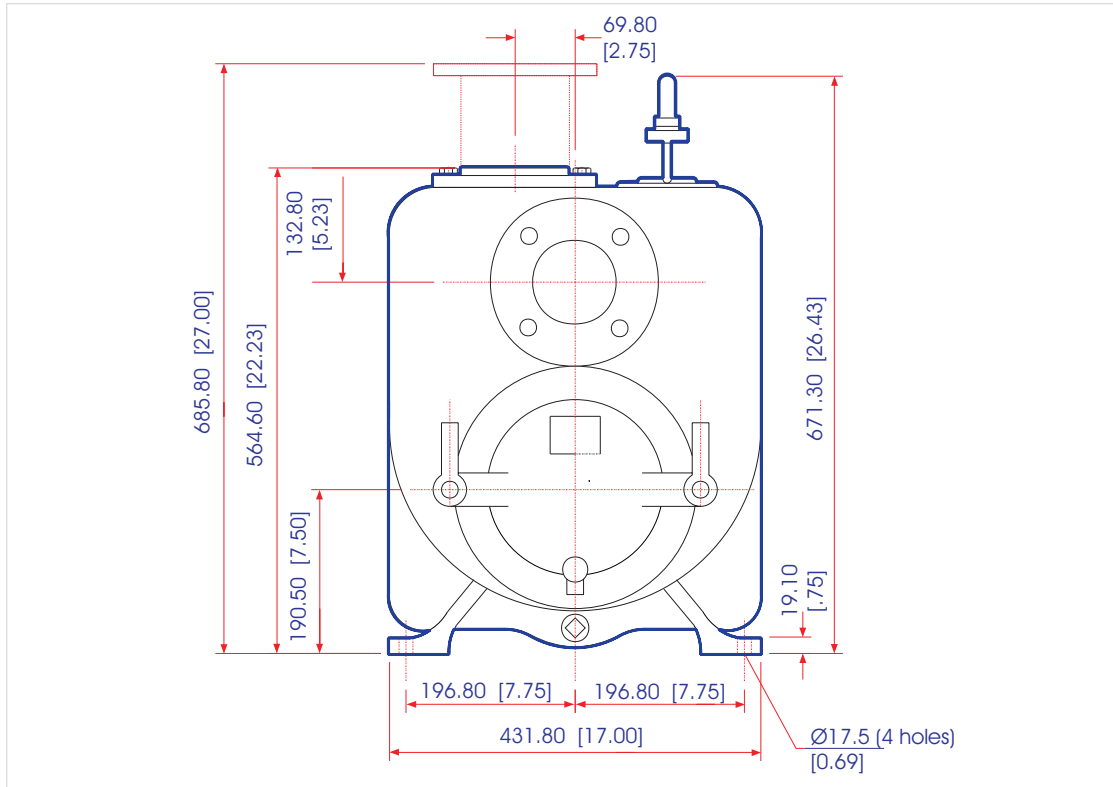



DATA SHEET

NET WEIGHT 272kg (600lbs)
SHIPPING WEIGHTS 297kg (655lbs)
IMPELLER DIA. 279,4mm (11")
R.P.M. FROM 850rpm TO 2150rpm
MAX. SOLIDS 28.57mm (1.1/8")

SELF-PRIMING

850 RPM 2,4m (8ft) - 1150 RPM 3,0m (10ft)
 1450 RPM 3,6m (12ft) - 1750 RPM 3,9m (13ft)
 1950 RPM 4,5m (15ft) - 2150 RPM 5,2m (17ft)

BEFORE USING THIS TABLE, CHECK THE NPSH.

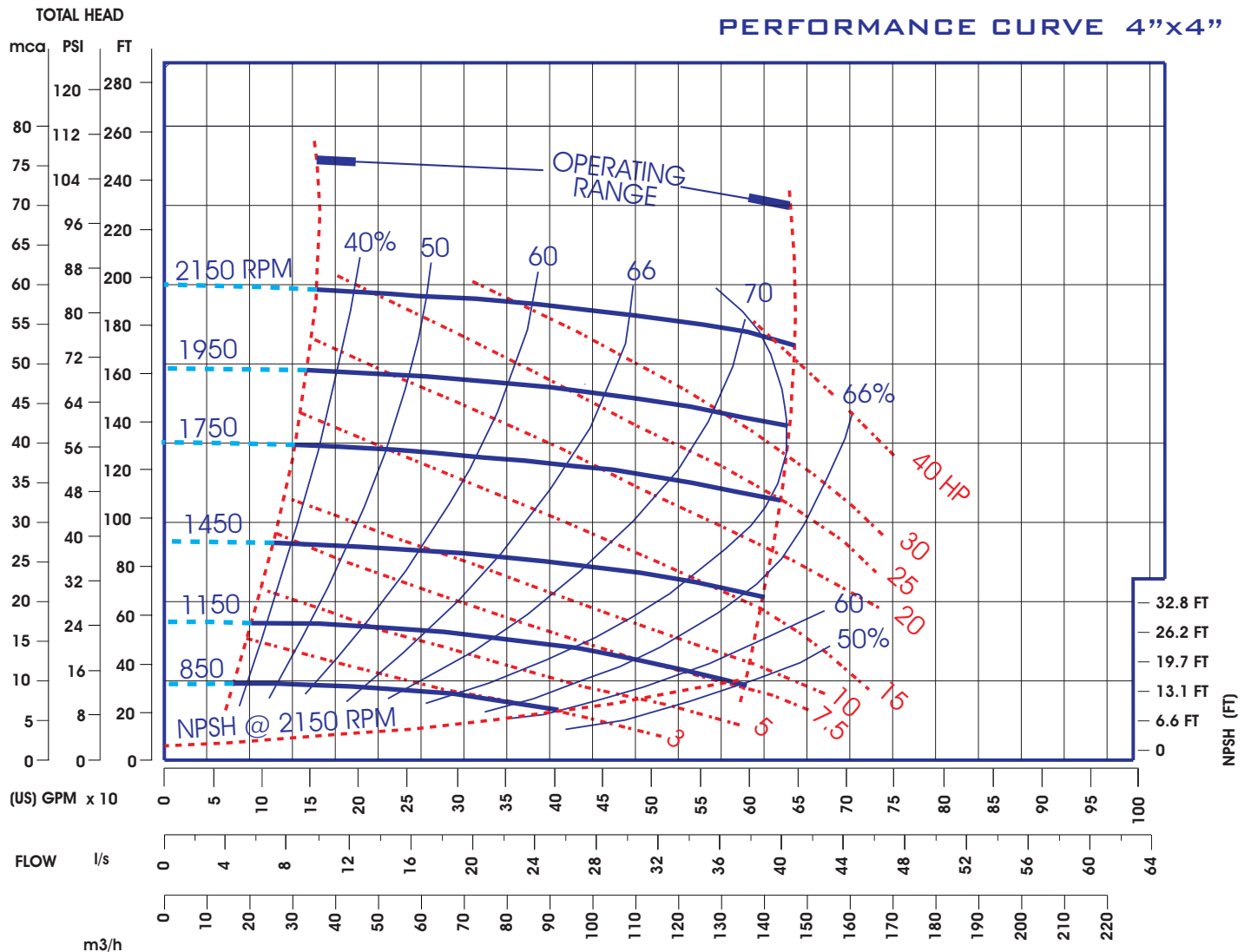

EXTERNAL DIMENSIONS
MILLIMETERS (INCHES)

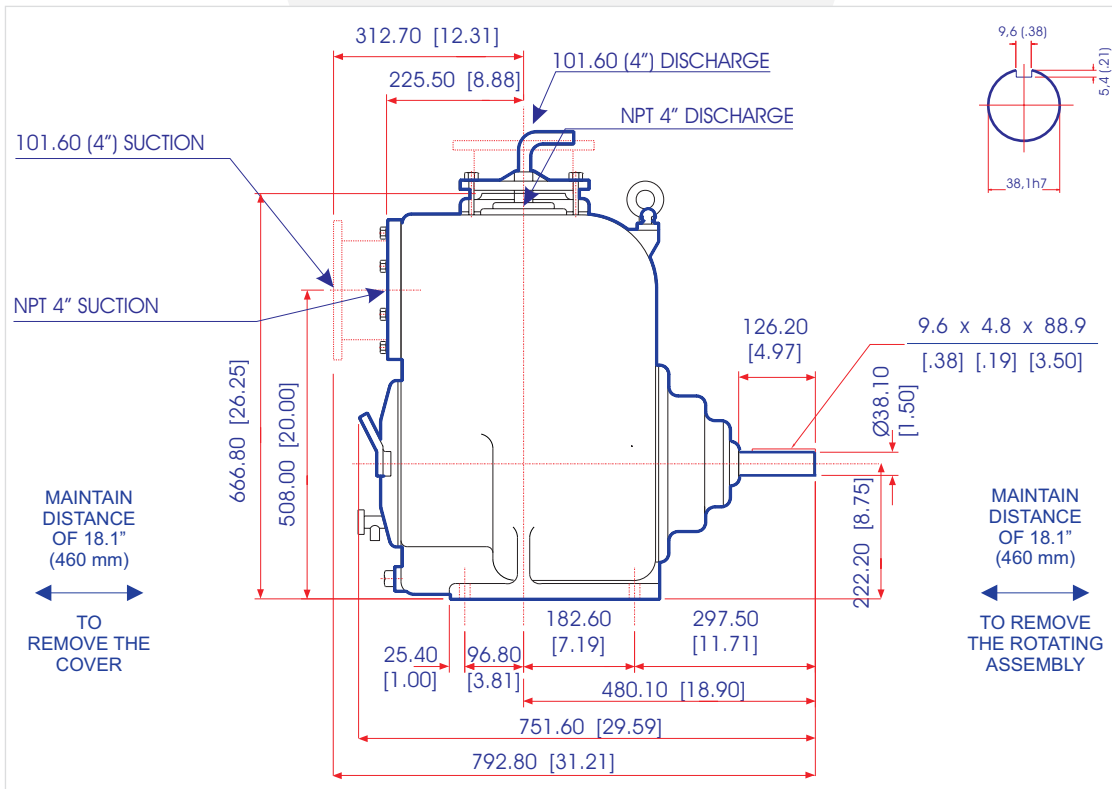
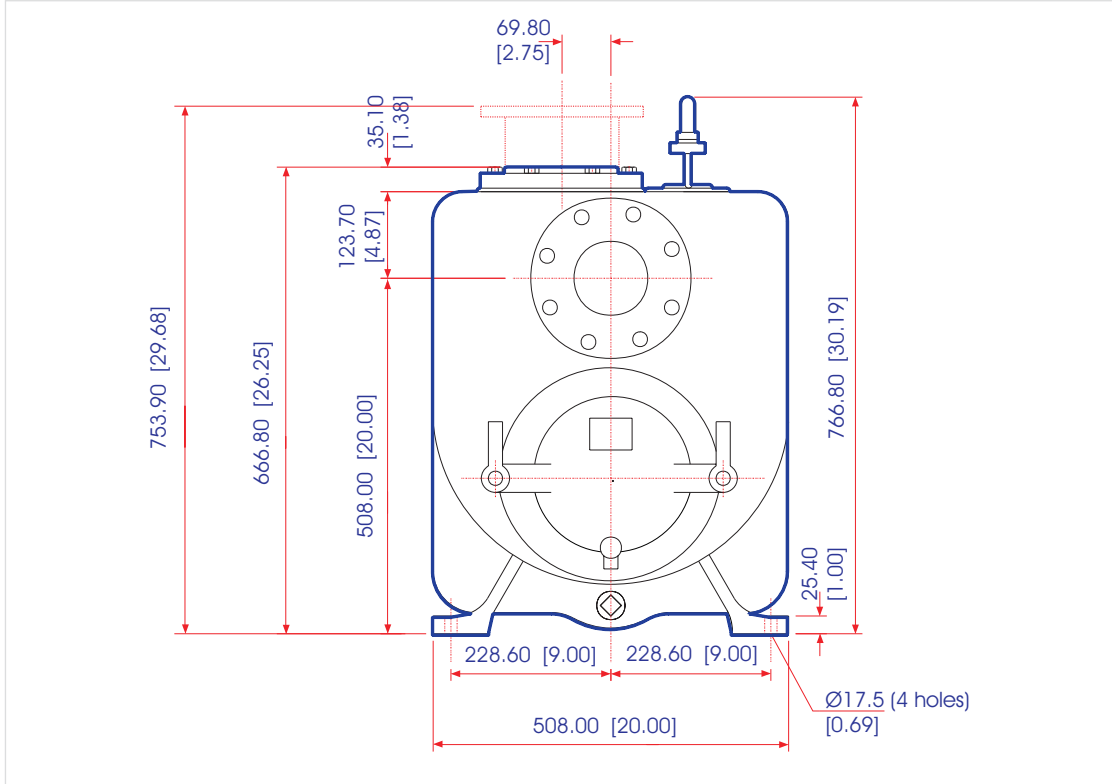



KTP

KAMYAR TAJHIZ POOYA CO.

SERIES H

MODEL H-6



DATA SHEET

NET WEIGHT 413kg (910lbs)
SHIPPING WEIGHTS 437kg (965lbs)
IMPELLER DIA. 317,5mm (12.1/2")
R.P.M. FROM 850rpm TO 1950rpm
MAX. SOLIDS 31,75mm (1.1/4")

SELF-PRIMING

850 RPM 2,4m (8ft) - 1150 RPM 3,0m (10ft)
 1450 RPM 4,2m (10ft) - 1750 RPM 4,5m (15ft)
 1950 RPM 4,5m (15ft)

BEFORE USING THIS TABLE, CHECK THE NPSH.

PERFORMANCE CURVE 6"x6"

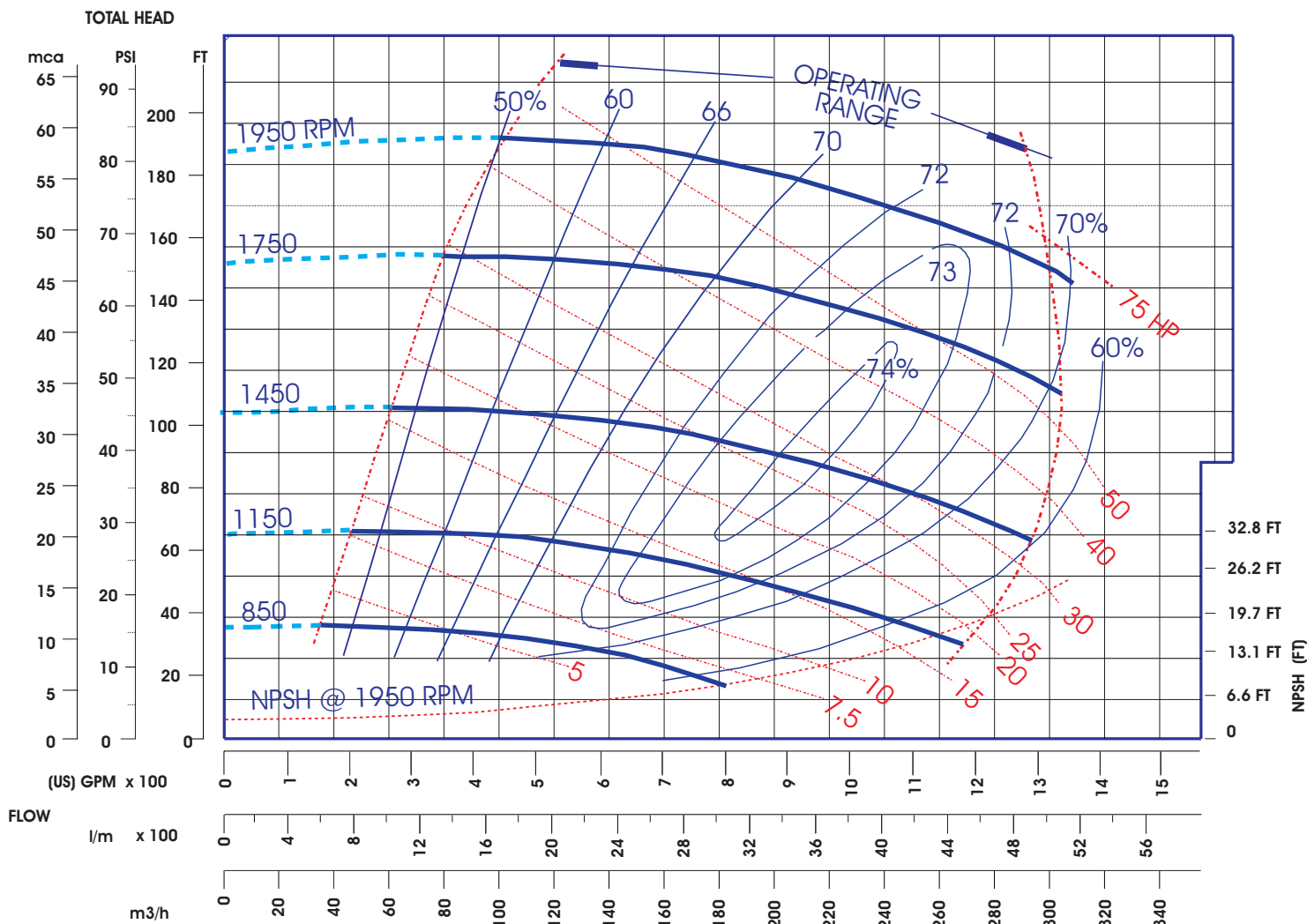

EXTERNAL DIMENSIONS
MILLIMETERS (INCHES)

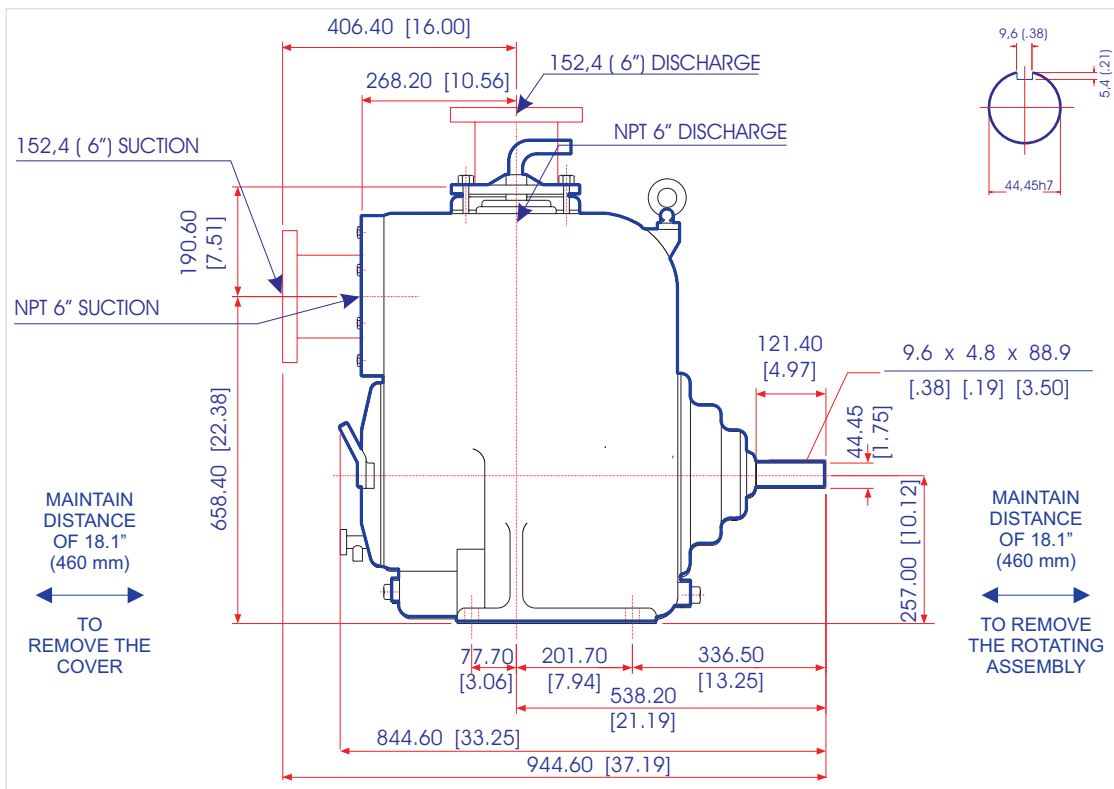
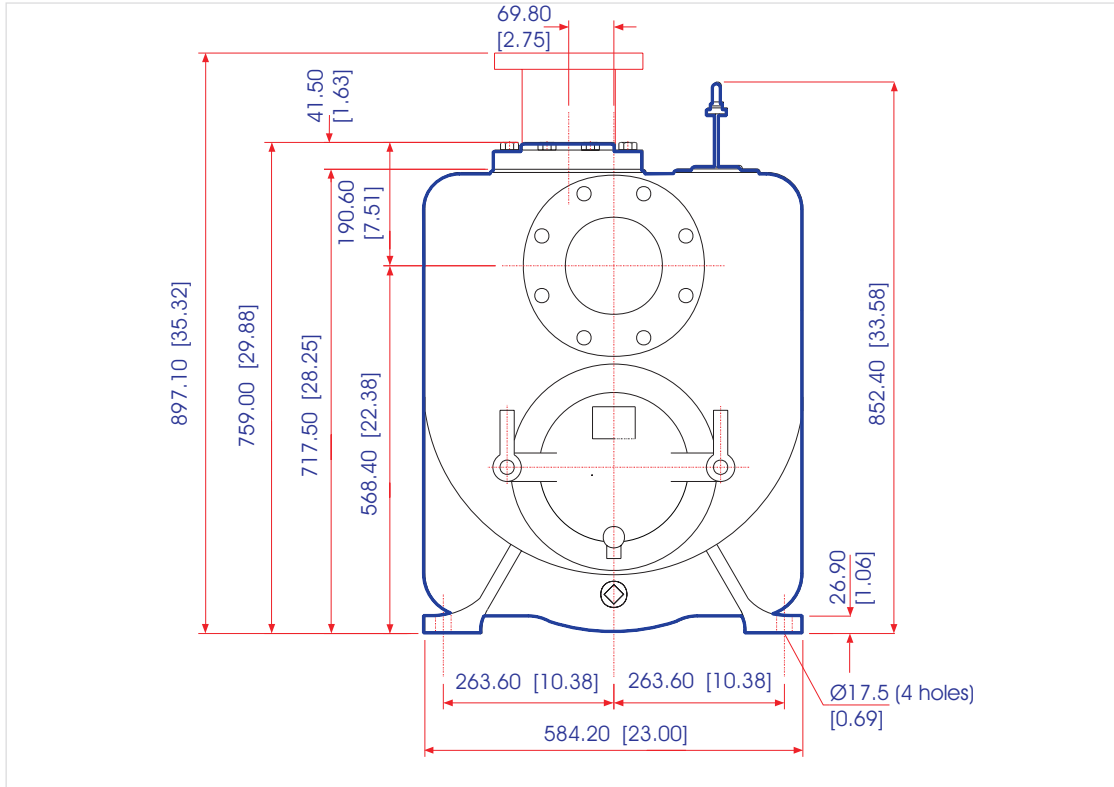

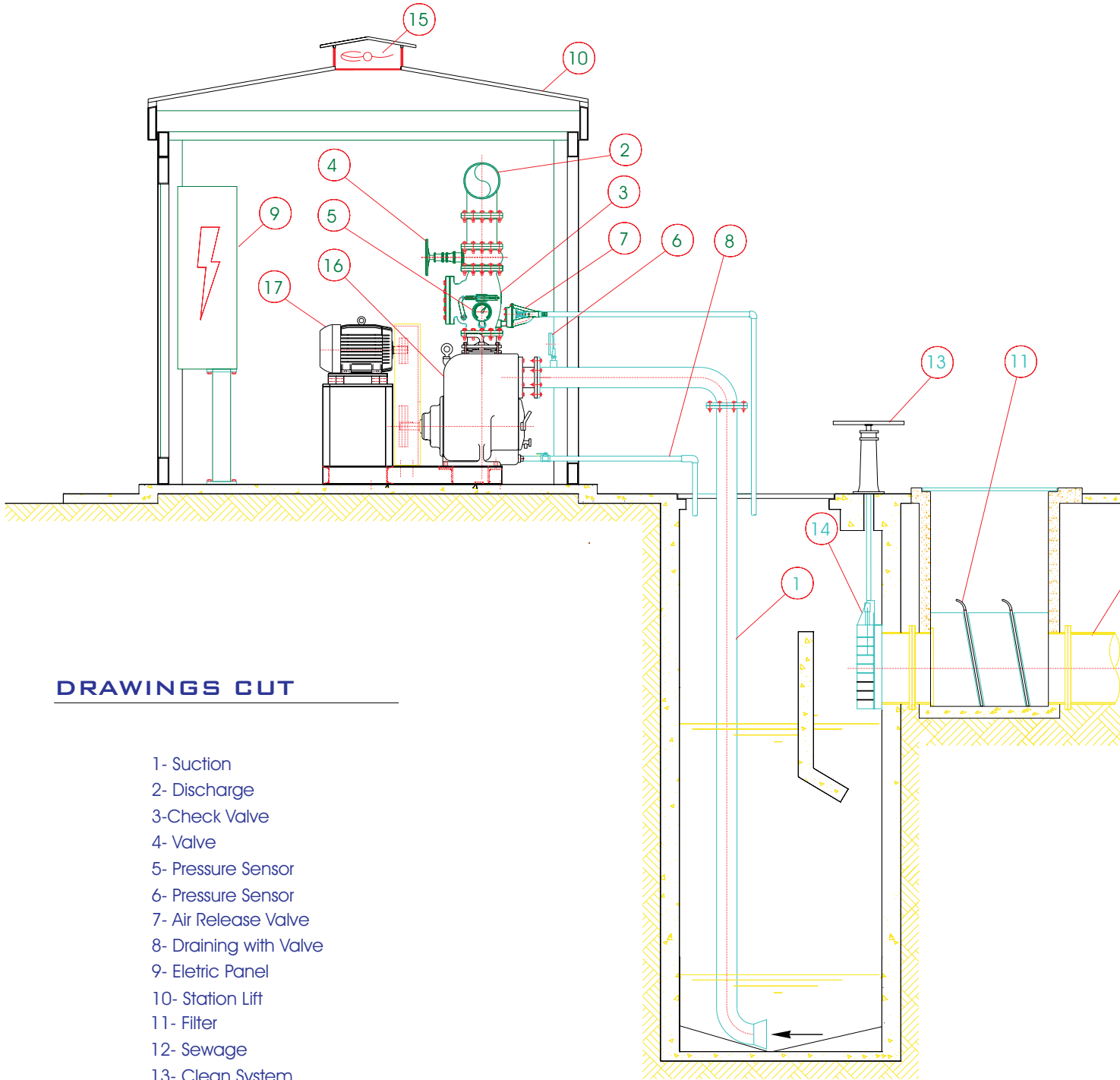

DRAWINGS CUT

- 1- Suction
- 2- Discharge
- 3- Check Valve
- 4- Valve
- 5- Pressure Sensor
- 6- Pressure Sensor
- 7- Air Release Valve
- 8- Draining with Valve
- 9- Electric Panel
- 10- Station Lift
- 11- Filter
- 12- Sewage
- 13- Clean System
- 14- Valve
- 15- Fan
- 16- Esco Pump (Series P or H)
- 17- Electric Motor