



Customer Success Story

FILMTEC™ Membranes

FILMTEC™ Membranes Reclaim Waste Water at 86% Recovery in Singapore

FAST FACTS

Location

Singapore

Purpose

Supply low-cost, high-grade industrial water from tertiary-treated waste water.

Comparative Performance

86% recovery of waste water in Singapore is now an industry benchmark.



SUT Seraya operates the reverse osmosis system that uses FILMTEC™ fouling resistant membranes to supply high quality industrial water to Singapore industry. This view shows the pressure vessel racks of three of the six reverse osmosis trains. (Photo courtesy of SUT Seraya.)

Industry in Singapore is thriving, creating a demand for high-quality process water destined to exceed the available supply. This situation prompted Singapore officials and industry to explore other sources of process water. A reverse osmosis plant using FILMTEC™ fouling resistant elements provided the answer. The membranes process tertiary-treated waste water effluent and convert it to high-grade industrial water. The plant has been operating successfully since 2000, supplying low-cost, high-grade industrial water to Singapore's petrochemical industry.

Introduction

Singapore is a small island-state with few natural resources and a population of 4 million. About half of the country's potable water supply comes from neighboring Malaysia through two supply agreements that expire in 2011 and 2061. To ease the strain on the potable water supply and reduce costs, the Jurong industrial area began to use industrial water as early as the 1970s. Industrial water is tertiary-treated sewage effluent reclaimed from the Ulu Pandan Water Reclamation Plant.

However, there was still a need for higher grade process water—a need

that increased as industry continued to grow on what is now known as Jurong Island. Surveys conducted in the mid-1990s indicated that an estimated 50,000 m³/day of higher grade water would be required by the petrochemical and chemical plants planning to build on the island.

In 1997, Singapore officials and industry began to look for alternative sources of high-grade water that would be less expensive and more widely available than potable water. FILMTEC™ fouling resistant membranes provided a technical solution to help them achieve this goal.

FILMTEC™ Membranes

FILMTEC™ fouling resistant elements are thin-film, spiral-wound polyamide composite membranes that are resistant to biofouling. Superior automated element construction technology results in a level of precision that is impossible to achieve with manually rolled elements. The higher number of shorter membrane leaves in a FILMTEC™ fouling resistant element results in reduced pressure loss on the permeate side, yielding higher efficiency, more uniform net driving pressure, and a more uniform permeate flux distribution.

FILMTEC™ fouling resistant elements are very durable and can be cleaned at pH 12. They are also highly resistant to bacterial adhesion. These features extend the time between cleanings and reduce cleaning costs.

Water Issues and Projected Needs

The Jurong Industrial Water Works (JIWW) produces industrial water (IW) by treating effluent from the Ulu Pandan Water Reclamation Plant. Because the intrusion of seawater affects water composition, chloride levels in IW vary between 100 and 500 mg/L. Conductivity fluctuates between 800 and 2,000 µS/cm, corresponding to total dissolved solids (TDS) of 500 to 1,200 mg/L.

Plant Construction and Design

SUT Seraya, a subsidiary of SembCorp Utilities Pte Ltd, operates the reverse osmosis system, which was designed and built by Aquatech International Corporation. The system includes two dual media filtration pretreatment stages to achieve a target silt density index (SDI) of 4 or less.

A lower rate of biomass accumulation and biofouling on FILMTEC™ fouling resistant elements results in lower average feed pressure to operate a reverse osmosis facility, thus substantially reducing energy costs.

The FILMTEC™ BW30-365-FR2 element was used at the Singapore site. This element has a 34-mil feed spacer, which is 10 to 20% thicker than feed spacers in competing elements, making it easier to clean. FILMTEC™ BW30-365-FR2 has since been superseded by a new product, FILMTEC™ BW30-365-FR, which offers the same benefits and can also be used to purify water for potable applications.

The planned high-grade industrial water system (HGIW) was projected to produce water of a quality slightly better than potable. The specification for conductivity was targeted at <250 µS/cm compared to the specification for potable water at 300 to 350 µS/cm. Because of the fluctuation of conductivity in the IW supplied by JIWW, a conductivity specification corresponding to a TDS of 1,300 mg/L was set for IW feed. At an estimated demand of 50,000 m³/day, a 30,000 m³/day plant could supply HGIW to industries at a lower price than potable water, through a separate supply system.

Backwashing of the two pretreatment stages is staggered to ensure that filtration is always done through compacted beds, which helps maintain a stable SDI. Table 1 lists other design parameters.

Table 1: Design parameters for RO units.

Flow rate per train, m ³ /day (gpd)	5,000 (1,320,860)
Number of trains	6
Recovery (%)	85 – 86
Temperature, °C	25-35
Feed TDS, mg/L	1,300
Feed pH	6.2 – 7.4
Average flux, L/m ² /h (gfd)	<16.9 (<10)
Max. feed pressure, kPa (bar, psi)	980 (9.8, 140)

Energy costs are reduced by using variable frequency drives and interstage booster pumps. The booster pumps allow flushing of third-stage elements while the other stages are operating. Because of the nature of the water being treated and the high recovery conditions, saturation levels reached in the third stage are extremely conducive to fouling and scaling.

Third-stage permeate flushing removes precipitants before they become permanent. Table 2 describes the configuration of an individual train. Figure 1 illustrates train layout.

Table 2: Configuration of each RO train.

Configuration	Three stages (28-16-8)
Pressure vessels	52 with 7 elements per vessel
Elements	FILMTEC™ BW30-365-FR
Total elements in 1 train	364
Total elements in 6 trains	2,184

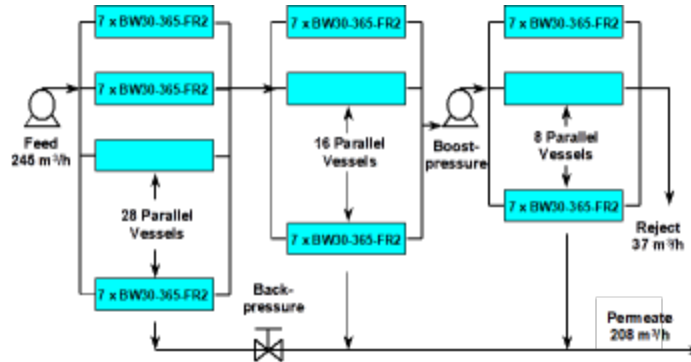

Figure 1: Layout of the RO train.

System Performance

Since the plant began operations in 2000, the reverse osmosis permeate has been well within specifications. Table 3 shows the effect of treatment on selected parameters of the feed water.

The raw effluent water can at times be high in SDI (>6) and TSS (6–6.5 mg/L), which can occasionally lead to an SDI in the feed to the RO system of >4. Figure 2 shows the trend in SDI in RO feed water from December 2000 to May 2001. When SDI levels in the feed water to the RO exceed 4 for an extended period of time, the plant recovery is typically reduced from 86% to 75%.

The time between cleanings was predicted to be once per month at 86% recovery. Cleanings are done every 4-5 weeks during which time the normalized permeate flow decreases by typically 15 to 20%.

After cleaning, the normalized flow returns to the original values. The chemistry of the FILMTEC™ membranes allows cleaning to be carried out at pH up to 12 (at 30°C) without negative impact on membrane performance. Generic cleaning chemicals are used.

After one year of operation, a routine membrane analysis was carried out. As expected, slight biofouling was observed and minor residues of Ca, Si, and Fe were detected, indicating mild colloidal fouling. Salt rejection and flow were within specification, which was expected since plant performance had not shown water deterioration, flux loss, or increased feed pressure.

Table 3: Actual values for selected parameters in feed water and RO permeate.

Parameter	Feed Water	RO Permeate
Conductivity, µS/cm	700 – 2,000	66 – 133
Total dissolved solids, mg/L	500 – 1,300	33 – 70
Turbidity, NTU	0.4 – 1.7	0.1 – 0.4
Total suspended solids, mg/L	1 – 2	0.07 – 0.13
Color, hazen unit	13	<5
Total hardness as CaCO ₃ , mg/L	100 – 160	1 – 3
Total alkalinity as CaCO ₃ , mg/L	40 – 80	16 – 22
Sodium, mg/L	150 – 200	10 – 12
Chloride, mg/L	150 – 200	6 – 21
Sulfate as SO ₄ , mg/L	120 – 160	<7
Silica as SiO ₂ , mg/L	6 – 10	0.1 – 0.4
Ammonia as N, mg/L	5 – 15	0.1 – 1.0
Phosphate as P, mg/L	2 – 4	0.04 – 0.10
Biological oxygen demand	<5	<1
Chemical oxygen demand	20 – 30	2 – 4
Bacteria, CFU/100 mL	<1,000	<1
Fluoride, mg/L	0.2 – 0.7	<0.02

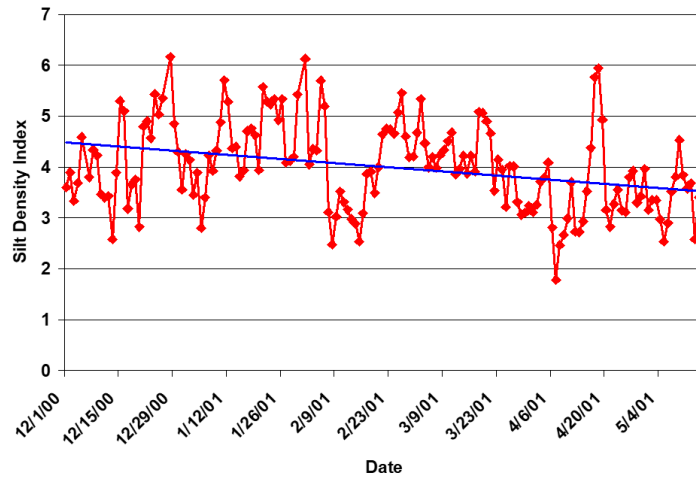

Figure 2: Silt density of feed water to the RO system (12/00 – 05/01).

Conclusions

Since start-up in January 2000, the reverse osmosis plant has performed well and reliably within the design specifications. The high recovery of 86% pioneered by this project is now considered to be an industry benchmark in tertiary effluent waste water reclamation.

The FILMTEC™ fouling resistant membranes have performed well under the stringent design and operating conditions imposed. Generic chemicals are adequate for cleaning, keeping the cost of cleaning low. This results in lower operating costs compared to older plants using membranes that are not designed to be resistant to fouling.

The high-grade industrial water provided by this reverse osmosis facility is less expensive than potable water. For customers using industrial water, HGIW also results in lower demineralization costs because the membranes remove most of the dissolved solids in the reclaimed water.

Altogether, this new reverse osmosis system using FILMTEC™ fouling resistant membranes is a win-win situation for Singapore. Industries now have access to process water that is less expensive than potable water, yet cleaner than industrial water, and Singapore conserves precious fresh water. This technology can be used in other parts of the world to reclaim waste water where water is scarce, thus preserving vital natural resources.

Have a question? Contact us at:

www.dupont.com/water/contact-us

All information set forth herein is for informational purposes only. This information is general information and may differ from that based on actual conditions. Customer is responsible for determining whether products and the information in this document are appropriate for Customer's use and for ensuring that Customer's workplace and disposal practices are in compliance with applicable laws and other government enactments. The product shown in this literature may not be available for sale and/or available in all geographies where DuPont is represented. The claims made may not have been approved for use in all countries. Please note that physical properties may vary depending on certain conditions and while operating conditions stated in this document are intended to lengthen product lifespan and/or improve product performance, it will ultimately depend on actual circumstances and is in no event a guarantee of achieving any specific results. DuPont assumes no obligation or liability for the information in this document. References to "DuPont" or the "Company" mean the DuPont legal entity selling the products to Customer unless otherwise expressly noted. NO WARRANTIES ARE GIVEN; ALL IMPLIED WARRANTIES OF MERCHANTABILITY OR FITNESS FOR A PARTICULAR PURPOSE ARE EXPRESSLY EXCLUDED. No freedom from infringement of any patent or trademark owned by DuPont or others is to be inferred.

DuPont™, the DuPont Oval Logo, and all products, unless otherwise noted, denoted with a ™, ℠ or ® are trademarks, service marks or registered trademarks of affiliates of DuPont de Nemours Inc. Copyright © 2019 DuPont de Nemours Inc. All rights reserved.

