

BEERFILTER MF 6" Hollow Fiber Cartridges

Hollow Fiber Crossflow Cartridges for Beer Filtration

PRODUCT DESCRIPTION	
Membrane Type:	Microfiltration
Membrane Material:	Polysulfone
Nominal Pore Size:	0.5 µm
Housing Construction:	Polysulfone shell and end caps
Regulatory Status:	Compliant with US FDA CFR Title 21 and EC Reg. Nos. 1935/2004, and 10/2011
Storage Solution:	Glycerin

SPECIFICATIONS			
Part Number	Model	Feed Spacer mil (mm)	Active Membrane Area ft ² (m ²)
KDP3358	BEERFILTER MF 6043	52 (1.3)	106 (10)

*Consult KSS Process Technology Group for specific applications.

PRODUCT DESCRIPTION	
Recommended Inlet Pressure:	40 psi (2.7 bar)
Maximum Transmembrane Pressure (TMP):	25 psi (1.7 bar)
Maximum Feed Side Pressure Drop:	30 psi (2.1 bar)
Maximum Backflush TMP:	20 psi (1.4 bar)
Operating Temperature Range²:	28°F (-2°C) - 50°F (10°C)
Operating pH Range:	3.5 - 9
Maximum Cleaning Temperature:	122°F (50°C)
Allowable Cleaning pH:	1.5 – 13.0
Maximum Total Chlorine During Cleaning:	200 ppm @ pH >11 under 104°F (40°C)

1 Consult KSS Industrial Process Technology Group for specific information

2 Thermal shocks must be avoided

NOMINAL DIMENSIONS

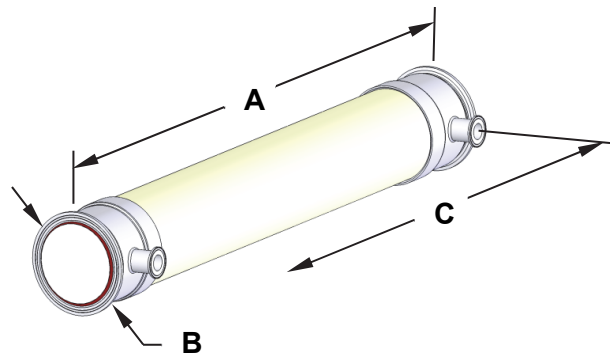

Model	A		B		C		Permeate Connection	Process Connection
	inches	(mm)	inches	(mm)	inches	(mm)		
BEERFILTER MF 6043	43	(1,090)	6.67	(169)	38 ¹¹ / ₁₆	(983)	1" sanitary	6" sanitary

6" HOLLOW FIBER CARTRIDGE HARDWARE

Item	Description	KPN
1	6" Gasket	0090424
2	6" Process Cap Adapter	0040321
3	6" Coupling	1020262
4	2 1/2" Cartridge Gasket	EPDM 0090411 BUNA 0090410
5	2 1/2" Coupling	0210468
6	1" Gasket	EPDM 0090394 BUNA 0090395
7	1" Coupling	0210465

Process pass kit for 6" cartridge with EPDM gaskets is available. KSS part number is 1007055.

Lubricants

For cartridge installation, use only water or glycerin to lubricate seals. The use of petroleum or vegetable-based oils or solvents may damage the cartridge and will void the warranty.

Exposure to Chemical Oxidants:

Exposure to chemical oxidants for thorough cleaning and sanitization may prove necessary and useful.

- Chemical oxidants commonly used in food applications include peracetic acid blends, hydrogen peroxide, sodium percarbonate, and sodium hypochlorite. Please consult KSS for recommended addition rates, frequency of use, and tolerance.
- Potassium metabisulfite (without catalyst such as cobalt) is the preferred chemical to eliminate residual chlorine or similar oxidizers prior to processing the feed stream.

KSS Capability

KSS is the leader in crossflow membrane technology, manufacturing reverse osmosis, nanofiltration, microfiltration, and ultrafiltration membranes and membrane systems. The industries served include food, dairy and beverage, pharmaceutical, biotechnology, water and wastewater, semiconductors, automotive, chemical and general manufacturing. KSS adds value by providing top quality membrane products and by sharing its experience in the design and supply of thousands of crossflow membrane systems worldwide.

Service and Ongoing Technical Support

Koch Separation Solutions, Inc. has an experienced staff of professionals available to assist end-users and OEMs for optimization of existing systems and support the development of new applications.

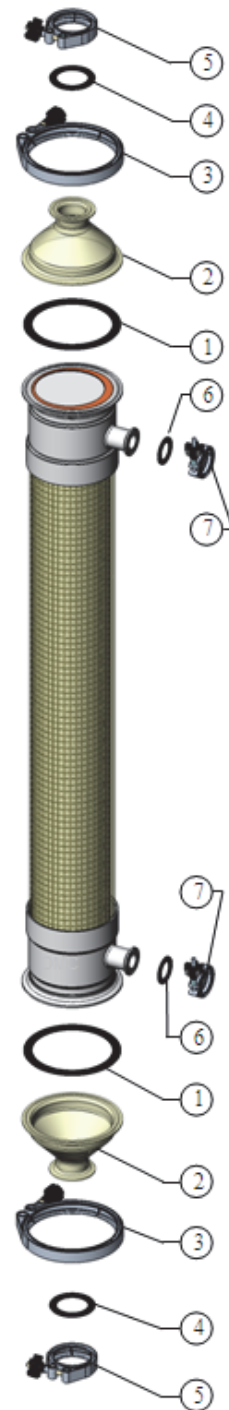

The information contained in this publication is believed to be accurate and reliable, but is not to be construed as implying any warranty or guarantee of performance. We assume no responsibility, obligation or liability for results obtained or damages incurred through the application of the information contained herein. Refer to Standard Terms and Conditions of Sale and Performance Warranty documentation for additional information

Koch Separation Solutions, Inc. 850 Main Street, Wilmington, MA 01887

Main: +1-978-694-7000 • Fax: +1-978-657-5208 • Toll Free: +1-888-677-5624

For complete contact information and listing of our global locations, visit www.kochseparation.com

©2020 Koch Separation Solutions, Inc. All rights reserved worldwide. For related trademark information, visit www.kochseparation.com/legal.