

CAUTION: INCORRECT MANIFOLDING WILL CAUSE SEVERE LOCAL STRESS AROUND PORT AND MAY RESULT IN LEAKS AND PREMATURE FAILURE; TAKE EVERY PRECAUTION LISTED ON PAGE 02, SEE INSTALLATION INSTRUCTIONS FOR FURTHER DETAILS

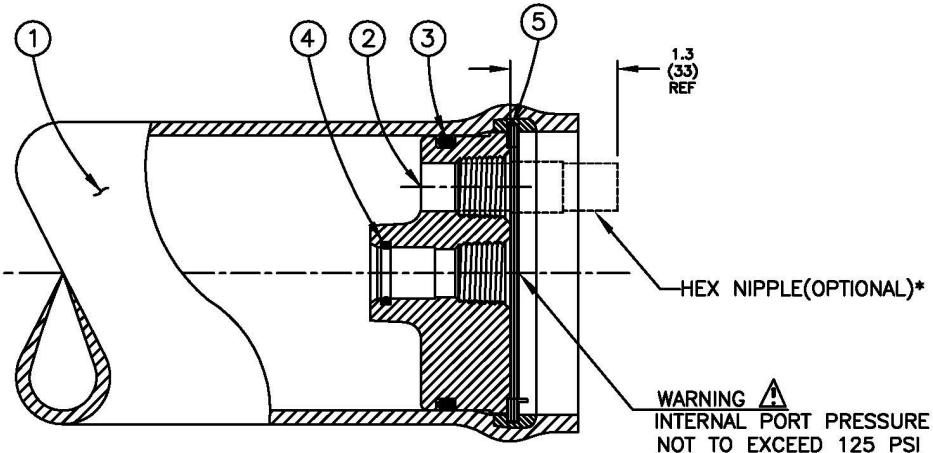

- NOTES**
- DIMENSIONS IN INCHES (MM APPROX)
 - NOT TO BE USED FOR CONSTRUCTION UNLESS CERTIFIED
 - SHELL EXTERIOR COATED WITH BLUE RAL 5010, HIGH GLOSS POLYURETHANE PAINT
 - DIRECT CONNECT—NO SUPPLY OF ADAPTERS
 - FOR HEX NIPPLE PART NOS. REFER PAGE 2

DWG REF	QTY	PART NUMBER	DESCRIPTION	MATERIAL
SHELL				
1	1	418093	SHELL	Filament Wound Epoxy/Glass composites - Head locking grooves integrally wound in place.
HEAD				
2	2	95927	End plug Sub-assembly	Engineering Thermoplastic.
3	2	45317	Head Seal	Ethylene Propylene - O - Ring
4	2	45296	PWT Seal	Ethylene Propylene - O - Ring
HEAD INTERLOCK				
5	2	45260	Retaining Ring	SA-479 SS 316
VESSEL SUPPORT				
6	2	45058	Saddle	Engineering Thermoplastic.
7	2	47459	Strap Assembly	304 Stainless Steel-PVC Cushion.
8	4	97821	Strap screw	5/16-18 UNC, 1.5" L, 18-8 Stainless Steel.

Dash Length	L IN(MM)	S IN(MM)	Approx Weight LB(KG)
-1	44.12 (1121)	28X1 (711)	9 (4)
-2	84.12 (2137)	56X1 (1422)	16 (7)
-3	124.12 (3153)	80X1 (2032)	23 (10)

PENTAIR
CODELINE®

DRAWN DATE	AXA 11JUL05	MODEL - 40E30N		
CHECKED DATE	MD 11JUL05	LOW PRESSURE MEMBRANE HOUSING		
APPROVED DATE	RM 11JUL05	ECN 5491	DWG. NO. 518016	REV. P
		DATE 22SEP20	SCALE NONE	SIZE B SHEET 1 OF 2

RATING:

DESIGN PRESSURE.....	300 PSI (2.07 Mpa)
MAX. OPERATING TEMP.....	120°F (49°C)
MIN. OPERATING TEMP.....	20°F (-7°C)
FACTORY TEST PRESSURE.....	450 PSIG (3.10 MPa)
BURST PRESSURE.....	1800 PSI (12.41 MPa)

INTENDED USE:

The Model 40E30N Fiberglass RO/UF Pressure Vessel is designed for continuous, long term use as housing for reverse osmosis and ultrafiltration elements in typical industrial water treatment systems at pressures up to 300 psi. Any make of four-inch nominal diameter spiral-wound element with a ¾" dia male product water tube is easily accommodated.

The Model 40E30N must be installed, operated and maintained in accordance with the listed precautions and good industrial practice to assure safe operation over a long service life.

The high performance reinforced plastic shell must be allowed to expand under pressure; undue restraint at support points or piping connections can cause leaks to develop in the shell. The end closures, incorporating close-fitting, interlocking metal components, must be kept dry and free of corrosion; deterioration can lead to catastrophic mechanical failure of the heads.

Pentair will assist the purchaser in determining the suitability of this standard vessel for their specific operating conditions. The final determination however, including evaluation of the standard material of construction for compatibility with the specific corrosive environment, shall be the responsibility of the purchaser. Alternate materials with enhanced corrosion resistance are available on special order.

Specifications are subject to change without notice.

NOTE
Spiral Retaining Ring Removal Tool (50303)
Recommended to open and close vessel.

PRECAUTIONS:

- DO...read, understand and follow all instructions; failure to take every precaution will void warranty and may result in vessel failure
- DO...mount the shell on horizontal members at span "S" using complaint vessel supports furnished; tighten hold down straps just snug
- DO...provide flexibility in, and support for piping manifolds so that vessel can grow in length under pressure without undue restraint; provide additional flexible joints in large pipes leading to manifold header
- DO...provide overpressure protection for vessel set at not more than 105% of design pressure
- DO...inspect end closures regularly; replace components that have deteriorated and correct causes of corrosion
- DO NOT...work on any component until first verifying that pressure is relieved from vessel
- DO NOT... make rigid piping connections to ports or clamp vessel in any way that resists growth of fiberglass shell under pressure; ΔDIA = 0.01 in. (0.25mm) and ΔL = 0.03 in. (0.8mm) for a length code -1 vessel
- DO NOT... hang piping manifolds from ports or use vessel in any way to support other components.
- DO NOT... operate vessel at pressures and temperatures in excess of its rating
- DO NOT... operate vessel without element installed
- DO NOT... operate vessel with permeate pressure in excess of 125 psi at 120°F (0.86 MPa @ 49°C)
- DO NOT... overtighten the connection to the permeate port (hand-tighten plus one-quarter turn, check for leaks)
- DO NOT... tolerate leaks or allow end closures to be routinely wetted in any way
- DO NOT... pressurize vessel until double-checking to verify that the retaining ring is completely inside the groove
- DO NOT... operate outside the pH range 3-11

CAUTION:
EYE PROTECTION SHOULD BE WORN WHEN REMOVING OR INSTALLING RETAINING RINGS. KEEP FINGERS CLEAR FROM RETAINING RING WHILE INSTALLING LAST OF TWO TURNS. RING MAY SNAP INTO POSITION POSSIBLY PINCHING FINGERS.

ORDERING:

Using the chart below, please check the features you require and fax them with your purchase order to our customer service department for expedited processing.
For optional materials and/or features not listed below, please consult factory for pricing and availability.

Please note that we require your membrane brand and model number when ordering. If this information is not initially available, you may provide it at a later date by checking the appropriate box below.

VESSEL LENGTH CODE – please check one

MODEL 40E30N -1 -2 -3

MEMBRANE BRAND AND MODEL – please check one and fill in information

- Please supply end plugs for the following membrane brand and specific model
Brand _____ Model _____
- Membrane brand and model information is not available, but will be supplied to Pentair on or before the following date ____/____/____

CERTIFICATION – please check one

- CE Marked.(Not applicable for -1 vessel)

EXTERIOR FINISH – please check one

- Standard – Blue high-gloss RAL 5010 polyurethane coating over sanded surface.
- Optional – White high-gloss RAL 9003 polyurethane coating over sanded surface.

Serial number	Opposite	
End	End	

- | | | |
|--------------------------|--------------------------|---------------------------|
| <input type="checkbox"/> | <input type="checkbox"/> | END PLUG MATERIALS |
| <input type="checkbox"/> | <input type="checkbox"/> | Standard – Noryl |
| <input type="checkbox"/> | <input type="checkbox"/> | Optional - PVC |

- | | | |
|--------------------------|--------------------------|------------------------------------|
| <input type="checkbox"/> | <input type="checkbox"/> | PERMEATE PORT CONFIGURATION |
| <input type="checkbox"/> | <input type="checkbox"/> | Standard – ½" NPT Female |

- | | | |
|--------------------------|--------------------------|--------------------------------|
| <input type="checkbox"/> | <input type="checkbox"/> | FEED PORT CONFIGURATION |
| <input type="checkbox"/> | <input type="checkbox"/> | Standard – ¾" NPT Female |
| <input type="checkbox"/> | <input type="checkbox"/> | Optional – ½" NPT Female |

- | | | |
|--------------------------|--------------------------|---|
| <input type="checkbox"/> | <input type="checkbox"/> | HEX NIPPLE CONFIGURATION FOR FEED PORT |
| <input type="checkbox"/> | <input type="checkbox"/> | Optional – ¾" NPT Male PVC (p/n 98752) |
| <input type="checkbox"/> | <input type="checkbox"/> | Optional – ¾" BSPT Male PVC (p/n 98790) |

For complete information on proper use of the vessel
Please refer to 40E30N USER'S GUIDE - 526003