

Electric self-cleaning screen filter FMA 5000

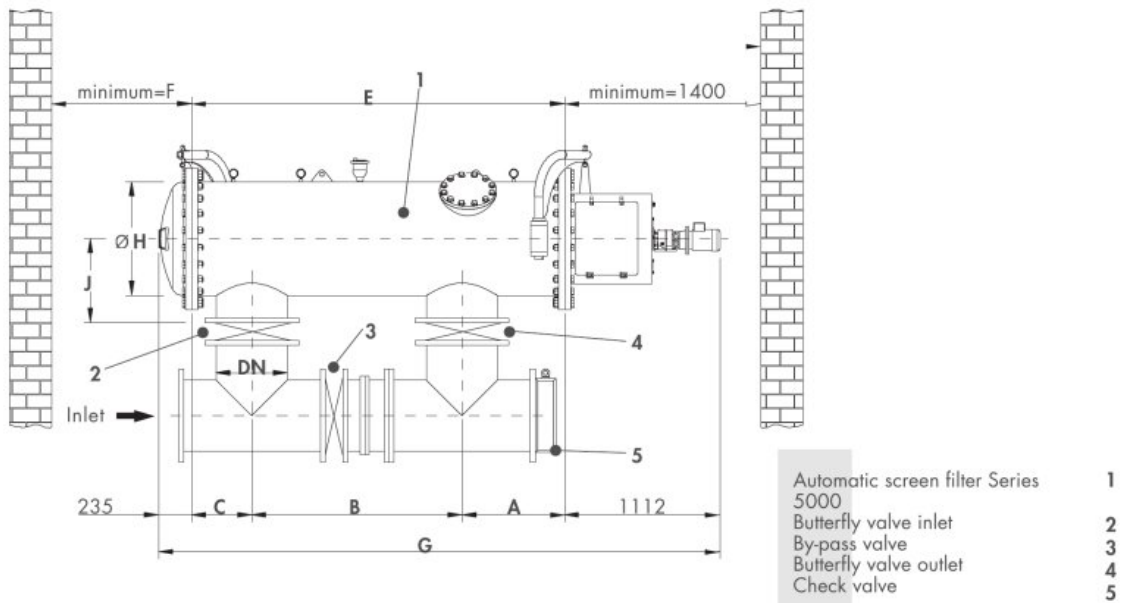

Model	Dimensions (mm)									Filtering surface (cm ²)	Weight (kg.)
	A	B	C	DN	E	F	G	H	J		
FMA-5020	733	1500	430	500	2663	1400	4010	812	600	55.000	1810

Model	Filtration degree	Max. flow	Flow rate (m ³ /h)		
			High Quality	Medium Quality	Low Quality
FMA-5020	50 microns	2000	1250	1000	800
	25 microns	1800	750	500	300